

# Constructivist and Ecological Rationality in Economics<sup>†</sup>

By VERNON L. SMITH\*

When we leave our closet, and engage in the common affairs of life, (reason's) conclusions seem to vanish, like the phantoms of the night on the appearance of the morning; and 'tis difficult for us to retain even that conviction, which we had attained with difficulty ... (David Hume, 1739, 1985, p. 507).

... we must constantly adjust our lives, our thoughts and our emotions, in order to live simultaneously within different kinds of orders according to different rules. If we were to apply the unmodified, uncurbed rules (of caring intervention to do

visible "good") of the ... small band or troop, or ... our families ... to the (extended order of cooperation through markets), as our instincts and sentimental yearnings often make us wish to do, *we would destroy it*. Yet if we were to always apply the (competitive) rules of the extended order to our more intimate groupings, *we would crush them* (Friedrich A. Hayek, 1988, p. 18; italics are his, parenthetical reductions are mine).

We have become accustomed to the idea that a natural system like the human body or an ecosystem regulates itself. To explain the regulation, we look for feedback loops rather than a central planning and directing body. But somehow our intuitions about self-regulation do not carry over to the artificial systems of human society. (Thus) ... the ... disbelief always expressed by (my) architecture students (about) ... medieval cities as marvelously patterned systems that had mostly just "grown" in response to myriads of individual decisions. To my students a pattern implied a planner ... . The idea that a city could acquire its pattern as "naturally" as a snowflake was foreign to them (Herbert Alexander Simon, 1981, 1996, p. 33).

Historically, a recurrent theme in economics is that the values to which people respond are not confined to those one would expect based on the narrowly defined canons of rationality. These roots go back to Adam Smith (1759, 1776), who examined the moral sympathies that characterize natural human sociality.<sup>1</sup> Contrary to vulgar impressions, in Smith's view, each individual defined and pursued his own interest in his own way, and individuals were mischaracterized

<sup>†</sup> This article is a revised version of the lecture Vernon L. Smith delivered in Stockholm, Sweden, on December 8, 2002, when he received the Bank of Sweden Prize in Economic Sciences in Memory of Alfred Nobel. The article is copyright © The Nobel Foundation 2002 and is published here with the permission of the Nobel Foundation.

The title was suggested to the author in the paper by Joel Norman, "Two Visual Systems and Two Theories of Perception: An Attempt to Reconcile the Constructivist and Ecological Approaches" (*Behavioral and Brain Sciences*, 2002). After finishing this paper I found that my use of the term below had been used by Gerd Gigerenzer et al. (1999), for application to "fast and frugal decision making," by individuals: "A heuristic is ecologically rational to the degree that it is adapted to the structure of an environment" (p. 13). Hayek, in the citations below, identifies both kinds of rationality.

\* Department of Economics and Law, Interdisciplinary Center for Economic Science, George Mason University, 4400 University Drive, MSN 1B2, Fairfax, VA 22030. Doing experimental economics has changed the way I think about economics. There are many reasons for this, but one of the most prominent is that designing and conducting experiments forces you to think through the process rules and procedures of an institution. Few, like Einstein, can perform detailed and imaginative mental experiments. Most of us need the challenge of real experiments to discipline our thinking. In this paper I hope to indicate how my thinking has been changed in some detail. I am indebted to Sid Siegel for technical and conceptual inspiration; to John Hughes, Stan Reiter, and the Purdue University faculty from 1955 to 1967 for warm, tolerant support beginning with my first experiment; to Charles Plott, Charles Holt, and Martin Shubik for many valuable encounters over the years on institutional and experimental issues; to students, visitors, the current ICES team, and especially to my growing but tolerating family who have made all these years the best years of my life.

<sup>1</sup> Economists are largely untouched by Smith's first great work, which was eclipsed by the *Wealth of Nations*. Thus, one of the profession's best-known historian of economic thought, "found these two works in some measure basically inconsistent" (Jacob Viner, 1991, p. 250). For a contrary interpretation see Smith (1998). Many of the references herein to my own and coauthored work have been reprinted in Smith (1991, 2000).

by the metaphor, “economic man.” (cf., Hayek, 1991, p. 120). This careless scholarship fails to recognize the key proposition articulated by the Scottish philosophers: to do good for others, does **not** require deliberate action to further the perceived interest of others. As Mandeville so succinctly put it, “The worst of all the multitude did something for the common good.” (See Mandeville’s poem, “The Grumbling Hive” or “Knaves Turned Honest,” 1705; quoted in Hayek, 1991, p. 82.) Many contemporary scholars, and not only popular writers, have reversed Mandeville’s proposition, and argued that the standard socioeconomic science model (SSSM) requires, justifies, and promotes selfish behavior.<sup>2</sup> On the contrary, because enforceable rights can never cover every margin of decision, opportunism in all relational contracting and exchange across time are costs, not benefits, in achieving long-term value from trade; an ideology of honesty<sup>3</sup> means that people play the game of “trade,” rather than “steal,” although crime may often pay the rational lawbreaker who always chooses dominant strategies. Nor does nonselfish behavior in ordinary market transactions prevent those transactions from promoting specialization and creating wealth.

Cultures that have evolved markets have enormously expanded resource specialization, created commensurate gains from exchange, and are wealthier than those that have not. This proposition says nothing about the necessity of human selfishness—the increased wealth of particular individuals can be used for consumption, investment, to pay taxes, for MacArthur Fellows, gifted to the symphony, the Smithsonian, or the poor.<sup>4</sup>

<sup>2</sup> That A implies B in no sense allows the reverse statement. But why would we economists confuse necessary with sufficient conditions? The text from Hume provides the answer. No one can consistently apply rational logical principles to everything he or she does; if there are cognitive costs in every application then the effort cost will often exceed the benefits (Smith and Fercen Szidarovszky, 2003). Theorists live by proving theorems, and when in this mode we rarely make such errors. A missing chapter in the study of bounded rationality is its application to understanding, and accepting with a little humility, the severe limitations it imposes on our development of economic theory.

<sup>3</sup> Douglass Cecil North (1981) has emphasized the importance of ideology in promoting economic growth.

<sup>4</sup> In the Potlatch, some wealth—created in part by private property rights in fishing grounds—was publicly destroyed.

Markets economize on the need for virtue, but do not eliminate it.

Research in economic psychology<sup>5</sup> has prominently reported examples where “fairness” considerations are said to contradict the rationality assumptions of the standard socioeconomic science model. But experimental economists have reported mixed results on rationality: people are often better (e.g., in two-person anonymous interactions), in agreement with (e.g., in flow supply and demand markets), or worse (e.g., in asset trading), in achieving gains for themselves and others than is predicted by rational analysis. Patterns in these contradictions and confirmations provide important clues to the implicit rules or norms that people may follow, and can motivate new theoretical hypotheses for examination in both the field and the laboratory. The pattern of results greatly modifies the prevailing, and I believe misguided, rational SSSM, and richly modernizes the unadulterated message of the Scottish philosophers.

## I. On Two Forms of Rationality

The organizing principle throughout this paper is the simultaneous existence of two rational orders. I shall try to make the case that both orders are distinguishing characteristics of what we are as social creatures; that both are essential to understanding and unifying a large body of experience from socioeconomic life and the experimental laboratory, and in charting relevant new directions for economic theory as well as experimental-empirical programs.

### A. Constructivist Rationality

The first concept of a rational order derives from the SSSM going back to the seventeenth century. The SSSM is an example of what Hayek has called constructivist rationality (or “constructivism”), which stems particularly

<sup>5</sup> I will use the term “economic psychology” generally to refer to cognitive psychology as it has been applied to economic questions, and to a third subfield of experimental methods in economics recently product-differentiated as “behavioral economics” (Sendhil Mullainathan and Richard H. Thaler, 2001), and further differentiated into “behavioral game theory” (Colin F. Camerer, 2002); the original foundations were laid by W. Edwards, Danny Kahneman, Anatol Rapoport, Paul Slovic, and Amos Tversky to name some of the most prominent.

from Descartes (also Bacon and Hobbes),<sup>6</sup> who believed and argued that all worthwhile social institutions were and should be created by conscious deductive processes of human reason.<sup>7</sup> In economics the SSSM leads to rational predictive models of decision that motivate research hypotheses that experimentalists have been testing in the laboratory since the mid-twentieth century. Although the test results tend to be confirming in impersonal market exchange, the results are famously and recalcitrantly mixed in “personal exchange,” notably in a great variety of two-person extensive-form games where some half of the people attempt and frequently succeed when risking cooperation, even when anonymously paired.<sup>8</sup> These results have motivated constructivist extensions of game theory based on other-regarding, in addition to own-regarding, preferences (e.g., Gary E Bolton, 1991; Matthew Rabin, 1993), and on “learning”—the idea that the predictions of the SSSM might be approached over time by trial-and-error adaptation processes (Ido Erev and

Alvin E. Roth, 1998; Camerer and Teck-Hua Ho, 1999).

An alternative and perhaps complimentary explanation of some of these contradictions to theory is that people may use social-grown norms of trust and reciprocity<sup>9</sup> (including equity, meaning to each according to his justly earned dessert; i.e., equality of opportunity, not outcome) to achieve cooperative states superior to individually rational defection outcomes. We will report some experimental tests designed to separate competing preference and reciprocity theories of behavior in personal exchange. Although reciprocity seems to be a leader in the comparisons we summarize, its strength is not uniform across all tests, and much remains to be learned about the hidden recesses of meaning in human behavior and the circumstances in which cooperative or noncooperative behavior is manifest.<sup>10</sup> Technically, the issue is how most productively to model agent “types” by extending game theory so that types are an integral part of its **predictive** content, rather than merely imported as an *ex post* technical explanation of experimental results. For example, moves can signal types, and effect decision, which explains why game form matters, and why payoffs available, but forgone, can effect outcomes. These elements must be part of the internal structure of the theory such that outcomes become predictions conditional on the elementary characteristics of players who read each other’s intentions. If successful, many of the basic results in game

<sup>6</sup> In the nineteenth century, Bentham and John Stuart Mill were among the leading constructivists. Bentham (and the utilitarians) sought to “... remake the whole of ... (British) ... law and institutions on rational principles” (Hayek, 1960, p. 174). Mill introduced the much-abused constructivist concept of (but not the name) “natural monopoly.” To Mill it was transparently wasteful and duplicative to have two or more mail carriers operating on the same route. He is the intellectual father of the U.S. and other postal monopolies around the world, their resistance to innovation, and their demise in the face of the privatization movement in some countries and the growth of superior substitutes in others. Mill could not imagine that it would be efficient for two cities to be connected by two parallel railroad tracks (Mill, 1899, Vol. 1, pp. 131, 141–42; Vol. 2, p. 463). Mill died in 1873. I would conjecture that by that date, or soon thereafter, men with grade-school educations had become rich constructing the first parallel-route railroads. These emergent contradictions to constructivist natural monopoly are examples of what we shall call ecological rationality, as detailed below.

<sup>7</sup> “... Descartes contended that all the useful human institutions were and ought to be deliberate creation(s) of conscious reason ... a capacity of the mind to arrive at the truth by a deductive process from a few obvious and undoubtable premises” (Hayek, 1967, p. 85).

<sup>8</sup> Behavioral economists have made a cottage industry of showing that the SSSM assumptions seem to apply almost nowhere to real decisions. This is because their research program has been a deliberate search in the tails of distributions for “Identifying the ways in which behavior differs from the standard model ...” (Mullainathan and Thaler, 2001, Vol. II, p. 1094), a search that can only succeed.

<sup>9</sup> Dissatisfied with the utilitarian approach because its predictions fail to account for the observed importance of instructions/procedures, we began investigating the reciprocity hypothesis in Elizabeth Hoffman et al. (1994). Mechanically, utilities can serve as intermediate placeholders for reciprocal trust, but, as surface indicators, serve poorly to generate new hypotheses designed to understand interactive processes. Good theory must be an engine for generating testable hypotheses, and utility theory runs out of fuel quickly. Utility values are seen as providing the ultimate “given” data, and the conversation stops.

<sup>10</sup> I am reminded of a department head from Hewlett-Packard visiting our lab. I naively assumed that he would be most interested in demonstrations of some of our market experiments. Not so. He was more interested in the “trust” experiments. Why? He saw the HP management problem as one of getting teams to cooperate internally by building trust and trustworthiness, while being vigorous competitors externally. Could the trust games serve as a measurement and teaching tool for helping to solve this problem? This nicely illustrates the tension in Hayek’s two-worlds quote in the text.

theory would become special cases of the extended theory.

In market experiments—where cooperation can occur through the coordination function of prices produced by, but simultaneously resulting from, interaction with individual choice behavior—the results are more commonly in accord with standard competitive models that maximize group welfare. This professional victory is hollowed by the failure of standard theory to predict the “surprisingly”<sup>11</sup> weak conditions under which the results obtain.<sup>12</sup>

Thus, for tractability, Cartesian rationalism provisionally assumes or “requires” agents to possess complete payoff and other information—far more than could ever be given to one mind. In economics the resulting exercises are believed to sharpen economic thinking, as if—then parables. Yet, these assumptions are unlikely to approximate the level of ignorance that has conditioned either individual behavior, or our evolved institutions, as abstract norms or rules independent of particular parameters, which have survived as part of the world of experience.<sup>13</sup> The temptation is to ignore this reality because it is poorly understood, and does not yield to our familiar but inadequate modeling tools, and to proceed in the implicit belief that our parables capture what is most essential

about what we observe. Having sharpened our understanding on Cartesian complete information parables we carry these tools into the world for application without all the necessary caveats that reflect the tractability constraints imposed by our bounded professional cognitive capacities as theorists.

In summary, constructivism uses reason to deliberately create rules of action, and create human socioeconomic institutions that yield outcomes deemed preferable, given particular circumstances, to those produced by alternative arrangements. Although constructivism is one of the crowning achievements of the human intellect, it is important to remain sensitive to the fact that human institutions and most decision making is not guided primarily, if at all, by constructivism. Emergent arrangements, even if initially constructivist in form, must have survival properties that take account of opportunity costs and environmental challenges invisible to our modeling efforts.

#### B. *Limitations and Distractions of Constructivist Rationality*

Since our theories and thought processes about social systems involve the conscious and deliberate use of reason, it is necessary to constantly remind ourselves that human activity is diffused and dominated by unconscious, automatic, neuropsychological systems that enable people to function effectively without always calling upon the brain’s scarcest resource—attentional and reasoning circuitry. This is an important economizing property of how the brain works. If it were otherwise, no one could get through the day under the burden of the self-conscious monitoring and planning of every trivial action in detail.<sup>14</sup> Also, no one can express in thoughts, let alone words, all that he or she knows, and does not know but might call upon, or need to discover, for some purposive action. Imagine the strain on the brain’s resources if at the supermarket a shopper were required to explicitly evaluate his preferences for every combination of the tens of thousands of grocery items that are feasible for a given

<sup>11</sup> Robert B. Wilson (1992, p. 256) discusses an efficiency theorem, and suggests that the phenomenon is “perhaps unsurprising.” It is, nowadays, but few believe it; also, theory has lagged well behind the evidence, and yields inadequate testable insight into the process dynamics operating in different institutions.

<sup>12</sup> I want to acknowledge correspondence with Charles Plott and add the following: Although this is a giant victory for the economic theory of markets it simultaneously demonstrates that the theory is incomplete. The unexpectedly weak conditions under which the results obtain are good news for market performance, but not such good news for the scientific community because it demonstrates that we do not understand why markets work as they do. You do not have to have large numbers of agents, each an insignificant part of the whole—three or four buyers and as many sellers are entirely adequate in a wide range of economic environments; they do not have to have complete or perfect or common information—each can have only private information; nor is it required that individuals make decisions systematically or be economically sophisticated.

<sup>13</sup> Throughout the paper I will use “environment” to mean the collection of agent values (preferences) that define the gains from trade; “institution” to refer to the language (messages), rules of message exchange, and contract in a market; and “behavior” for agent message choices conditional on the environment and institution (Smith, 1982).

<sup>14</sup> “If we stopped doing everything for which we do not know the reason, or for which we cannot provide a justification ... we would probably soon be dead” (Hayek, 1988, p. 68).

budget. Such mental processes are enormously opportunity-costly and implicitly our brain knows, if our conscious mind does not know, that we must avoid incurring opportunity costs that are not worth the benefit.<sup>15</sup> The challenge of any unfamiliar action or problem appears first to trigger a search by the brain to bring to the conscious mind what one knows that is related to the decision context. Context triggers autobiographic experiential memory, which explains why context surfaces as a nontrivial treatment, particularly in small group experiments. The brain (including the entire neurophysiological system) takes over directly in the case of familiar, mastered tasks, and plays the equivalent of lightening chess when the “expert” trades, plays Beethoven’s Fifth piano concerto, or connects with a 95-mile/hour fastball—all without self-aware “thinking” by the mind.

We fail utterly to possess natural mechanisms for reminding ourselves of the brain’s off-line activities and accomplishments. This important proposition has led Michael S. Gazzaniga (1998) to ask why the brain fools the mind into believing it is in control.<sup>16</sup> And to Hayek, who

thoroughly understood this proposition, what was the “fatal conceit”? “The idea that the ability to acquire skills stems from reason.” The constructivist mind makes a fatal “error,” blinding itself to understanding, as we are warned, “one should never suppose that our reason is in the higher critical position and that only those moral rules are valid that reason endorses” (Hayek, 1988, p. 21). But the anthropocentric (-morphic) mind routinely makes this significant error.

Most of our operating knowledge<sup>17</sup> we do not remember learning. Natural language is the most prominent example, but also music and virtually everything that constitutes our developmental socialization. We learn the rules of a language and of efficient social intercourse, without explicit instruction, simply by exposure to family and extended family social networks (Jerome Kagan and Sharon Lamb, 1987; Alan Page Fiske, 1991; Kagan, 1994; Steven Pinker, 1994). That the brain is capable of off-line subconscious learning is shown by experiments with amnesiacs who are taught a new task. They learn to perform well, but memory of having learned the task escapes them (Barbara J. Knowlton et al., 1996).

### C. Ecological Rationality

These considerations lead to the second concept of a rational order, as an undesigned ecological system that emerges out of cultural and biological evolutionary<sup>18</sup> processes: homegrown

<sup>15</sup> Expected utility theory is for teaching (as Wassily Leontief once suggested), but also for the constructivist modeling of consistent choice. It seems inadequate for the prediction, or the ecological understanding, of behavior. Its inadequacy for prediction has been plainly emphasized in the many contributions of Amos Tversky and Daniel Kahneman (see their 1987 paper for an excellent summary statement), some of which have been qualified and reinterpreted in the work of Gigerenzer et al. (1999). The results are far more encouraging in the context of markets, where subjects are not consciously maximizing. See, e.g., Smith (1991, 2000) and Plott (2001). Joyce Berg et al. (1994), in a significant paper, find that the measurement of risk aversion varies with the type of market institution or procedure used in extracting risk measures from decisions. See Smith and Szidarovszky (2003) for a constructivist utilitarian treatment of decision whose reward outcome requires cognitive costs to be incurred: objective rationality is not subjectively rational, and therefore it is not optimal for the individual to apply the objectively “optimal” prescriptions.

<sup>16</sup> “By the time we think we know something—it is part of our conscious experience—the brain has already done its work. It is old news to the brain, but fresh to ‘us.’ Systems built into the brain do their work automatically and largely outside of our conscious awareness. The brain finishes the work half a second before the information it processes reaches our consciousness. ... We are clueless about how all this works and gets effected. We don’t plan or articulate these actions. We simply observe the output. ... The brain begins to cover for this ‘done deal’ aspect of its functioning

by creating in us the illusion that the events we are experiencing are happening in real time—not before our conscious experience of deciding to do something” (Gazzaniga, 1998, pp. 63–64).

<sup>17</sup> Hayek (1967, p. 44) notes that “... modern English usage does not permit generally to employ the verb ‘can’ (in the sense of the German *konnen*) to describe all those instances in which an individual merely ‘knows how’ to do a thing ... (including) ... the capacity to act according to rules which we may be able to discover but which we need not be able to state in order to obey them.”

<sup>18</sup> Many recognize that evolutionary processes are necessarily coevolutionary, but there is also deep denial of this, and bias, that all is due to “culture” (which is even more poorly understood than biology), leading Pinker (2002) to investigate why. Heritable abstract function can become dormant, atrophied, or malfunctioning in the absence of initializing input on a developmental time schedule for the brain’s vision, language, and socialization circuitry. That these processes are coevolutionary is evident in the study of

principles of action, norms, traditions, and “morality.”<sup>19</sup> Ecological rationality uses reason—rational reconstruction—to examine the behavior of individuals based on their experience and folk knowledge, who are “naive” in their ability to apply constructivist tools to the decisions they make; to understand the emergent order in human cultures; to discover the possible intelligence embodied in the rules, norms, and institutions of our cultural and biological heritage that are created from human interactions but not by deliberate human design. People follow rules without being able to articulate them, but they can be discovered. This is the intellectual heritage of the Scottish philosophers, who described and interpreted the social and economic order they observed.

An eighteenth-century precursor of Herbert Simon, David Hume was concerned with the limits of reason, the bounds on human understanding, and with scaling back the exaggerated claims of Cartesian constructivism. To Hume, rationality was phenomena that reason discovers in emergent institutions. Thus, “the rules of morality ... are not conclusions of (our) reason.” (Hume, 1985, p. 235). Adam Smith developed the idea of emergent order for economics. Truth is discovered in the form of the intelligence embodied in rules and traditions that have formed, inscrutably, out of the ancient history of human social interactions. This is the antithesis of the anthropocentric belief that if an observed social mechanism is functional, somebody in the unrecorded past must have used reason con-

sciously to create it to serve its perceived intended purposes.<sup>20</sup>

In experimental economics the eighteenth-century Scottish tradition is revealed in the observation of emergent order in numerous studies of existing market institutions such as the continuous double auction (CDA).<sup>21</sup> To paraphrase Adam Smith, people in these experiments are led to promote group welfare-enhancing social ends that are not part of their intention. This principle is supported by hundreds of experiments whose environments and institutions (sealed bid, posted offer, and others besides CDA) may exceed the capacity of formal game-theoretic analysis to articulate predictive models. But they do not exceed the functional capacity of collectives of incompletely informed human decision makers, whose automatic mental algorithms coordinate behavior through the rules of the institution—social algorithms—to generate high levels of measured performance.

Acknowledging and investigating the workings of unseen processes are essential to the

---

twins (Nancy L. Segal, 1999). Deconstructivist reports argue that these studies exhibit many of the usual data and statistical identification problems (Arthur S. Goldberger, 1979), but the need is for positive revisionist analysis.

<sup>19</sup> “Morality” refers to any maxim of cohesive social behavior that survives the test of time, and is prominently represented by the great “shalt not” prohibitions of the leading world religions: thou shalt not: (1) steal, (2) covet the possessions of others, commit (3) murder, (4) adultery, or (5) bear false witness. The first two define and defend property rights in the product of one’s labor, and all resources accumulated by such labor, enabling the emergence of the extended order of mind through markets. The last three commandments protect the sanctity of social exchange—the external order of the mind. These modest exclusionary constraints leave an immense scope for freedom within their bounds. Corollaries, like the Buddhist live-and-let-live version of the golden rule, are explicit in this respect: “do not unto others as you would have them not do unto you.”

<sup>20</sup> In cultural and biological evolution, order arises from mechanisms for generating variation to which is applied mechanisms for selection. I am indebted to Todd Zywicki, who, at a recent Liberty Fund conference on “Hayek, Experiment and Freedom,” observed that reason is good at providing variation, but not selection. Constructivism is indeed an engine for generating variation, but is far too limited in its ability to comprehend and apply all the relevant facts to serve the process of selection, which is better left to ecological processes.

<sup>21</sup> What experimentalists have unintentionally brought to the table is a methodology for objectively testing the Scottish-Hayekian hypotheses under scientific controls. This answers the question Milton Friedman is said to have raised concerning the validity of Hayek’s theory/reasoning: “How would you know?” (I am unable to find/provide the reference). Remarkably, Hayek stated on the very edge of recognizing what experiments could do for testing his theory, then dismissed it. Thus, “We can test it (‘competition as a discovery procedure’) on conceptual models, and we might conceivably test it in artificially created real situations, where the facts which competition is intended to discover are already known to the observer. But in such cases it is of no practical value, so that to carry out the experiment would hardly be worth the expense” (Hayek, 1984, p. 255; also see Smith, 2002, pp. 95–96). Economic historians, e.g., North (1981), and political economists, e.g., Elinor Ostrom (1990), have long explored the intelligence and efficacy embodied in emergent socioeconomic institutions that solve, or fail to solve, problems of growth and resource management. They study “natural” ecological experiments from which we have learned immeasurably.

growth of our understanding of social phenomena, and enable us to probe beyond the anthropocentric limitations of constructivism.

Both kinds of rationality have influenced the design and interpretation of experiments in economics. Thus, if people in certain contexts make choices that contradict our formal theory of rationality, rather than conclude that they are irrational, some ask why, reexamine maintained hypotheses including all aspects of the experiments—procedures, payoffs, context, instructions, etc.—and inquire as to what new concepts and experimental designs can help us to better understand the behavior. What is the subjects' perception of the problem that they are trying to solve?

Finally, understanding decision requires knowledge beyond the traditional bounds of economics,<sup>22</sup> a challenge to which Hume and Smith were not strangers.<sup>23</sup> This is manifest in the recent studies of the neural correlates of strategic interaction (McCabe calls it neuroeconomics) using fMRI and other brain-imaging technologies. That research explores the neuro-correlates of intentions or "mind reading," and other hypotheses about information, choice, and own versus other payoffs in determining interactive behavior.

The above themes will be illustrated and discussed in a wide variety of examples drawn from economics, law, experimental economics, and psychology. I will begin with impersonal exchange through markets, drawing on the learning from experiments and field observations to illustrate how the contrast between constructive and ecological rationality informs learning from observation. Then I will examine personal exchange, particularly in the context of two-person extensive-form games, asking why constructivist models are of limited success in predicting behavior in single-play games, even when subjects are anonymously matched.

<sup>22</sup> I importune students to read narrowly within economics, but widely in science. Within economics there is essentially only one model to be adapted to every application: optimization subject to constraints due to resource limitations, institutional rules, and/or the behavior of others, as in Cournot-Nash equilibria. The economic literature is not the best place to find new inspiration beyond these traditional technical methods of modeling.

<sup>23</sup> Thus, for Hayek, "an economist who is only an economist cannot be a good economist."

## II. Impersonal Exchange: The Extended Order of the Market

### A. *How Are the Two Concepts of a Rational Order Related?*

Constructivism takes as given the social structures generated by emergent institutions that we observe in the world, and proceeds to model it formally. An example would be the Dutch auction or its alleged isomorphic equivalent, the sealed-bid auction (William Vickrey, 1961; Paul Milgrom and Robert J. Weber, 1982). Constructivist models need not ask why or how an auction institution arose or what were the ecological conditions that created it, or why there are so many distinct auction institutions. In some cases it is the other way around. Thus, revenue equivalence theorems show that the standard auctions generate identical expected outcomes, which, if taken literally, leave no modeled economic reason for choosing between them.

More generally, using rational theory, one represents an observed socioeconomic situation with an abstract interactive game tree. Contrarily, the ecological concept of rationality asks from whence came the structure captured by the tree? Why this social practice, from which we can abstract a particular game, and not another? Were there other practices and associated game trees that lacked survival properties and were successfully invaded by what we observe? There is a sense in which ecological systems, whether cultural or biological, must necessarily be, or are in the process of becoming, rational: they serve the fitness needs of those who unintentionally created them through their interactions. Constructivist mental models are based on assumptions about behavior, structure, and the value-knowledge environment. These assumptions might be correct, incorrect, or irrelevant, and the models may or may not lead to rational action in the sense of serving well the needs of those to whom the models apply. As theorists the professional charge for which we are paid is to formulate and prove theorems. A theorem is a mapping from assumptions into testable or observable implications. The demands of tractability loom large in this exercise, and to get anything much in the way of results it is necessary to consider both the assumptions and their implications as variables. Few game

theorists, building on the assumption that agents always choose dominant strategies, believed this to characterize the behavior of all agents in all situations. Hence, the near-universal justification of theory as an exercise in “understanding.” But the temptation is to believe that our “castles in the sky” (as W. Brock would say) have direct meaning in our worlds of experience and proceed to impose them where it may not be ecologically rational to do so.

To understand what is—the tip of the knowledge iceberg—requires understanding of a great deal that is not. In the laboratory we can not only rationally reconstruct counterfactuals, as in economic history, but also use experiments to test and examine their properties. Let us look at two contemporary examples.

1. *Deregulating Airline Routes.*—Airline route deregulation brought an unanticipated reorganization of the network, called the hub-and-spoke system. (See, e.g., George Donahue, 2002). This is an ecologically rational response, apparently anticipated by none of the constructivist arguments for deregulation, and predicted by no one. Nor could it have been uncovered, I submit, in 1978 by surveys of airline managers, or by marketing surveys of airline customers. Unknown to both managers and customers was the subsequently revealed decision preferences of customers who unknowingly favored frequency of daily departure and arrival times—a preference that had to be discovered through market experimentation. Nonstop service between secondary cities was simply not sustainable in a deregulated world of free choice. The only way to achieve efficiency, both the demand for frequency of service and profitable load factors, among secondary cities was for the flights to connect through hubs. Hence, the hypothesis that a rational ecological equilibrium emerged to dominate repeated constructivist attempts, by business entrants and start-ups, to satisfy an incompatible set of constraints provided by the microstructure of demand, profitability, and technology.

Might it have been otherwise if airport runway rights, or “slots,” had been an integral part of the deregulation of airline routes, and the time-of-day spot pricing of slots had emerged to reflect hub congestion costs? (Stephen Rassenti et al., 1982). We do not know, but the effect of this hypothetical counterfactual on the viability

of hub bypass could be assessed in laboratory experiments. As in all studies of what is not, the challenge is to estimate the parameters that would implement the appropriate economic environment.

2. *The California Energy Crisis.*—A second, and very troubling, example is the circumstances leading to the California energy crisis. As in other regions of the country and the world, deregulation was effected as a planned transition with numerous political compromises. In California it took the form of deregulating wholesale markets and prices while continuing to regulate retail prices at fixed hourly rates over the daily and seasonal cycles in consumption. The utilities negotiated an increase in these average retail rates to meet the revenue requirements of capital investments that were “stranded” (i.e., were believed to be unable to recover their costs under competition). This preoccupation with the past, and with average revenue/cost thinking by regulators and regulated alike, ill-prepared the state for the consequences of having no dynamic mechanisms for prioritizing the end use consumption of power.

As expected, traditional volatility in the marginal cost of generated electricity was immediately translated into volatile intra-day wholesale prices. What was not expected was that a combination of low rainfall (reducing Pacific Northwest hydroelectric output), growth in demand, unseasonably hot weather, generators down on normal maintenance schedules, etc., caused the temporary normal daily peaking of prices to be greatly accentuated, and to be much more lasting than had occurred earlier in the Midwest and South. Events of small probability happen at about the expected frequency, and since there are many such events the unexpected is not that unlikely. Constructivist planning failed to provide for retail competition to experiment with programs allowing consumers to save money by enabling their lower priority uses of power to be interrupted in times of supply stress. Interruptible deliveries are a direct substitute for both energy supply and energy reserves, and are an essential means of assuring adequate capacity and reserves that cover all the various supply contingencies faced by the industry.

Because of the regulatory mandate that all demand must be served at a fixed price, the

planning did not allow for the early introduction of demand responsive retail prices and technologies to enable peak consumption to be reduced. Instead of mechanism design we had fixed retail price “design” to generate average revenue that was supposed to cover average cost, and it failed. The regulatory thought process is as follows: the function of price is to provide revenue, and the function of revenue is to cover cost. But this is the antithesis of the market function of price. For neither management nor the regulators was it natural to think in terms of profiting from selling less power. Yet that was precisely the route by which the California distributors could have avoided the loss of an estimated \$15 billion: every peak kilowatt-hour not sold at the average retail rate would have saved up to ten times that amount of energy cost. Static technology, and the utter fantasy that all load can always be served, was protected from innovation by the legally franchised local wires monopoly. An entrant could not seek to win customers by offering discounts for switching from peak to off-peak consumption, and, at the entrant’s investment risk, installing the required control devices on end-use appliances. This legacy—long entrenched, and jealously sheltered by local franchised monopolies after deregulation—gave California dispatchers no alternative but to trap people in elevators and shut down high-end computer programming facilities at critical times of peak power shortage.

All power delivery systems are vulnerable to a combination of unfavorable events that will produce short supplies at peak demand. Constructivism alone, without competitive trial-and-error ecological experimentation with retail delivery technologies and consumer preferences, cannot design mechanisms that process all the distributed knowledge that individuals either possess or will discover, and that is relevant to finding an efficient mix of both demand and supply responsiveness.<sup>24</sup>

<sup>24</sup> This is illustrated by a November 6, 2002 press release by Puget Sound Energy. “PSE Proposes to End Pilot Time-of-Use Program Ahead of Schedule: PSE’s time-of-use (TOU) program was created in 2000 during the energy crisis and was intended to provide financial incentives for customers to shift some of their electricity consumption to less expensive, off-peak times of the day. The program was restructured in July 2002 to reflect a calmer energy market.

*Economic Systems Design.*<sup>25</sup>—What can we learn from experiments about how demand responsiveness could impact energy shortages as in the California crisis? Rassenti et al. (2003) measure this impact by creating a market in which a modest and achievable 16 percent of peak retail demand can be interrupted voluntarily at discount prices by wholesale energy providers. In the experiments, demand cycles through four levels each “day” and is expressed in the wholesale market with two contrasting experimental treatments: (1) robot buyers who reveal all demand at the spot market clearing price; (2) four profit-motivated human buyers who are free to bid strategically in the market to obtain the lowest available prices. In each case bids to supply power are entered by five profit-motivated human suppliers. In the passive-demand treatment prices average much above the benchmark competitive equilibrium, and are very volatile. In the treatment with human buyers, prices approach the competitive equilibrium, and price volatility becomes miniscule. By empowering wholesale buyers, in addition to sellers, to bid strategically in their own interest, even though 84 percent of peak demand is “must serve,” buyers are able to effectively discipline sellers and hold prices at competitive levels.<sup>26</sup>

---

Since that time it has resulted in most participants’ bills being slightly higher than on flat rates. ... Reynolds (a PSE spokesman, said) ‘However, when exploring new territory, you need to be able to recognize when the program is not working as you had hoped ... and begin a rigorous analysis of the program and how it could be successfully restructured for the future energy marketplace.’” It is because no one knows what will work best that you have to open retailing up to the field experiment called “free entry and exit.” One experimental possibility is a contract that would share the inherently unknown and unpredictable savings with the customer. When a total cannot be known in advance, use a proportionality rule. New Zealand’s tradable fish catch quotas were originally specified in quantities, and were redesigned as proportions of the changing quantity available (oral communication with Maurice McTigue, 2002). An advantage of laboratory experiments is that these kinds of errors are exposed, and corrective alternatives tested, at very low cost.

<sup>25</sup> I have never been comfortable with this label because it is reminiscent of the idea that we can engineer best social arrangements, which the reader will see is not my interpretation. See footnote 20.

<sup>26</sup> The most widely agreed-upon design failure in the California crisis was the rule preventing the distribution utilities from engaging in long-term contracts to supply

This example illustrates the use of the laboratory in economic systems design. In these exercises we can test-bed alternative market auction rules and the effect of transmission constraints on generator supply behavior (Steven R. Backerman et al., 2001), vary the degree of market concentration, or “power” in a nonconvex environment (Michael J. Denton et al., 2001), compare the effect of more or less strategic demand responsiveness (Rassenti et al., 2003), study network and multiple market effects also in a nonconvex environment (Mark Olson et al., 2003), and test-bed markets to inform, but not finalize, market liberalization policy (Rassenti et al., 2002). For a survey of many examples, see McCabe et al. (1991).

The two types of rational order are both expressed in the experimental methodology developed for economic systems design. This branch of experimental economics uses the lab as a test

---

power (Wilson, 2002, p. 1332). Beware this simplistic popular explanation: it is a two-wrongs-make-a-right argument: yes, of course, given that you were going to protect the monopoly power of the distribution utilities to tie the rental of the wires to the metering and sale of energy at a fixed regulated price, then one way to protect them temporarily from the consequent wholesale price volatility might be to encourage long-term contracts at a fixed average delivery cost. But suppliers will want higher prices and/or short-term contracts if they anticipate shortages—you cannot get blood out of a turnip; long contracts work to lower cost only to the extent that suppliers are surprised by high spot prices, but when it comes time to renegotiate expiring contracts they will not replicate the error. California discovered this when they intervened to sign long-term contracts, and encountered high prices. This whole argument turns the design problem on its head. You must (1) remove the legal power of the local wires monopoly to prevent competing energy suppliers from contracting with customers to discount off-peak energy, charge premiums for peak energy, and install the supporting control devices; (2) let this competition determine the dynamic price structure, and investment required to implement it; (3) simultaneously, let financial instruments evolve to hedge whatever risk is left over as prices become less volatile. Financial instruments can hedge price volatility, not load volatility. Only demand-responsive interruptible loads can relieve supply stress and provide the demand-side reserves that reduce the risk of lost load. No one mind or collective can anticipate and plan the needed mix of technologies to enable the market to manage demand. Therefore it is essential to remove all entry barriers, and allow firms to experiment through competition to discover and innovate efficient ways of organizing retail delivery systems. Claims that short-run retail demand is “notoriously” inelastic miss the point: how would you know if loan-shedding technology is inflexible? Competition and incentives to innovate have never been part of the structure.

bed to examine the performance of proposed new institutions, and modifies their rules and implementation features in the light of the test results. The proposed designs are initially constructivist, although most applications, such as the design of electricity markets or auctions for spectrum licenses, are far too complicated for formal analysis (Jeffrey Banks et al., 2003; Rassenti et al., 2003).

But when a design is modified in the light of test results, the modifications tested, modified again, retested, and so on, one is using the laboratory to effect an evolutionary adaptation as in the ecological concept of a rational order. If the final result is implemented in the field, it certainly undergoes further evolutionary change in the light of practice, and of operational forces not tested in the experiments because they were unknown, or beyond current laboratory technology.<sup>27</sup> In fact this evolutionary process is essential if institutions, as dynamic social tools, are to be adaptive and responsive to changing conditions. How can such flexibility be made part of their design? We do not know because no one can foresee what changes will be needed.

*Market Institutions and Performance.*—Non-cooperative or Cournot-Nash competitive equilibrium (CE) theory has conventionally offered two specifications concerning the preconditions for achieving a CE: (1) agents require complete, or “perfect,” information on the equations defining the CE; also common knowledge—all must know that all know that all know that they have this information. In this way all agents have common expectations of a CE and their behavior must necessarily produce it; (2) another tradition, popularly articulated in textbooks, and showing, perhaps, more sensitivity for plausibility, has argued for a weaker requirement that agents need only be price-takers in the market.

<sup>27</sup> People often ask, What are the limits of laboratory investigation? I think any attempt to define such limits is very likely to be bridged by the subsequent ingenuity and creativity (the primary barriers at any one time) of some experimentalist. Twenty-five years ago I could not have imagined being able to do the kinds of experiments that today have become routine in our laboratories. Experimentalists also include many of us who see no clear border separating the lab and the field.

The alleged “requirement” of complete, common, or perfect information is vacuous: I know of no predictive theorem stating that when agents have such information their behavior produces a CE, and in its absence their behavior fails to produce a CE. If such a theorem existed, it could help us to design the experiments that could test these dichotomous predictions. I suggest that the idea that agents need complete information is derived from introspective error: as theorists we need complete information to calculate the CE. But this is not a theory of how information or its absence causes agent behavior to yield or not a CE. It is simply an unmotivated statement declaring, without evidence, that every agent is a constructivist in exactly the same sense as are we as theorists. And the claim that it is “as if” agents had complete information, helps not a wit to understand the well-springs of behavior. What is missing are models of the process whereby agents go from their initial circumstances, and dispersed information, using the algorithms of the institution to update their status, and converge (or not) to the predicted equilibrium.<sup>28</sup>

<sup>28</sup> The inherent difficulty in equilibrium modeling of the CDA is shown by the fact that so few have even attempted. Wilson (1987), characteristically, has had the courage and competence to log progress. Daniel Friedman (1984) uses an unconventional no-congestion assumption to finesse Nash-Cournot analysis, concluding efficiency and a final competitive clearing price. Wilson (1987) uses standard assumptions of what is common knowledge—number of buyers (sellers), each with inelastic demand (supply) for one unit, preferences linear in payoffs, no risk aversion or wealth effects, valuations jointly distributed, and agent capacity to “compute equilibrium strategies and select one equilibrium in a way that is common knowledge” (p. 411). This is an abstract as-if-all-agents-were-game-theorists constructivist model of a thought process that no game theorist would or does use when participating in a CDA. The model itself generates its own problems, such as degeneracy in the endgame when there is only one buyer and seller left who can feasibly trade—a problem that is not a problem for the subjects, who do not know this, and see imperfectly informed buyers and sellers still attempting to trade and thereby disciplining price. Extra marginal traders provide opportunity cost endgame constraints on price. Agents need have no understanding of opportunity cost in order for their behavior to be shaped by it. Wilson recognizes these considerations: “The crucial deficiencies, however, are inescapable consequences of the game-theoretic formulation” (Wilson, 1987, p. 411). We are squarely up against the limitations—perhaps the dead-end ultimate consequences—of Cartesian constructivism. We have not a clue, any more than the so-called “naive” subjects in experiments, how it is that our brains so effortlessly solve the equilibration prob-

lem in interacting with other brains though the CDA (and other) institutions. We model not the right world to capture this important experimental finding.

As a theory the price-taking parable is also a nonstarter: who makes price if all agents take price as given? If it is the Walrasian auctioneer, why have such processes been found to be so inefficient? (Corrine Bronfman et al., 1996). Hundreds of experiments in the past 40 years (Smith, 1962, 1982; Douglas D. Davis and Charles A. Holt, 1993, 1995; John H. Kagel and Roth, 1995; Plott, 2001) demonstrate that complete information is not necessary for a CE to form out of a self-ordering interaction between agent behavior and the rules of information exchange and contract in a variety of different institutions, but most prominently in the continuous bid/ask double auction (CDA).<sup>29</sup> That complete information also may not be sufficient for a CE is suggested (the samples are small) by comparisons showing that convergence is slowed or fails under complete information in certain environments (Smith, 1976, 1980).

An interesting contribution by Dhananjay K. Gode and Shyam Sunder (hereafter GS; see Shyam Sunder, 2003, and the references it contains) is to demonstrate that an important component of the emergent order observed in these market experiments derives from the institution, not merely the presumed rationality of the individuals. Efficiency is necessarily a joint product of the rules of the institution and the behavior of agents. What Sunder and his coauthors have shown is that in the double-auction market for a single commodity (we know not yet how far it can be generalized), efficiency is high even with “zero” intelligence robot agents, each of whom chooses bids (asks) completely at random from

<sup>29</sup> See Jon Ketcham et al. (1984) for a comparison of CDA with the posted offer (PO) retail pricing mechanism. CDA converges more rapidly and is more efficient than PO. So why does not CDA invade and displace PO? It is the high cost of training every retail clerk to be an effective negotiator for the firm. Institutions reflect the fine structure of opportunity cost, and the loss of exchange efficiency in PO is more than offset by the distributional productive efficiency of the mass retailing innovation of the 1880’s that led price policy to be centralized. As I write, those policies are being modified on the Internet where prices can be adjusted to the opportunity cost characteristics of buyers, such as how many other Internet sites they have visited (Cary Deck and Bart Wilson, 2002). Institutional changes in response to innovations like mass retailing are part of the emergence of an ecologically rational equilibrium.

all those that will not impose a loss on the agent. Thus, agents who are not rational constructivist profit maximizers, and use no learning or updating algorithms, achieve most of the possible social gains from trade using this institution. Does this example illustrate in a small way those “super-individual structures within which individuals found great opportunities ... (and that) ... could take account of more factual circumstances than individuals could perceive, and in consequence ... is in some respects superior to, or ‘wiser’ than, human reason ... ”? (Hayek, 1988, pp. 77, 75).

We do not know if the GS results generalize to multiple market settings as discussed in the next paragraph. Ross M. Miller (2002), however, has shown that in a very elementary two-market environment—intertemporally separated markets for the same commodity—the GS results are qualified. Complex price dynamics, including “bubbles,” appear, and there is loss of efficiency, although the loss is not substantial. On average the decline is apparently from around 94 percent to 88 percent.

In multiple market trading in nonlinear interdependent demand environments, each individual’s maximum willingness-to-pay for a unit of commodity A depends on the price of B, and vice versa, and in this more complex economy double auction, markets also converge to the vector of CE prices and trading volumes. A two-commodity example is reported in Smith (1986), based on nonlinear demand (CES payoff function) and linear supply functions found in Arlington Williams and Smith (1986); also see Williams et al. (2000). In these experiments, numerical tables based on the preference and cost information defining the general-equilibrium solution of four nonlinear equations in two prices and two quantities are dispersed among the undergraduate subjects. They buy and sell units of each of the two commodities in a series of trading periods. Prices and trading volume converge, after several trading periods, to the CE defined by the nonlinear equations. The subjects would not have a clue as to how to solve the equations mathematically. The experimenter applies the tools of constructivist reason to solve for the benchmark CE, but in repeat play this “solution” emerges from the spontaneous order created by the subjects trading under the rules of the double-auction market institution. Numerous other experiments with many

simultaneous interdependent markets show similar patterns of convergence (Plott, 1988, 2001).

*The Iowa Electronic Market.*—What evidence do we have that the laboratory efficiency properties of continuous double auction trading apply also in the field? One of the best sources of evidence, I believe, is found in the Iowa Electronic Market (IEM) used widely around the world (Robert Forsythe et al., 1992, 1999). These markets are used to study the efficacy of futures markets in aggregating widely dispersed information on the outcomes of political elections, or any well-defined extra-laboratory event, such as a change in the discount rate by the Fed. The “laboratory” is the Internet. The “subjects” are all who log on and buy an initial portfolio of claims on the final event outcomes; they consist of whomever logs in, and are not any kind of representative or “scientific” sample as in the polls with which they are paired. The institution is the open-book double auction.

In the IEM, traders make a market in shares representing pair-mutual claims on the popular vote (or winner-take-all) outcome of an election, referendum, etc. For example, the first IEM was on the 1988 presidential election. Each person wanting to trade shares deposits a minimum sum, \$35, with the IEM and receives a trading account containing \$10 cash for buying additional shares, and ten elemental portfolios at \$2.50 each, consisting of one share of each of the candidates—Bush, Dukakis, Jackson, and “rest-of-field.” Trading occurs continuously in an open-book bid-ask market for several months, and everyone knows that the market will be called (trading suspended) in November on election day, when the dividend paid on each share is equal to the candidate’s fraction of the popular vote times \$2.50. Hence if the final two candidates and all others receive popular vote shares (53.2 percent, 45.4 percent, 1.4 percent), these proportions (times \$2.50) represent the payoff to a trader for each share held. Consequently, at any time  $t$ , normalizing on \$1, the price of a share ( $\div$  \$2.50) reflects the market expectation of that candidate’s share of the total vote. A price, \$0.43, means the market predicts that the candidate will poll 43 percent of the vote. Other forms of contract that can be traded in some IEMs include winner-take-all, or number of seats in the House, and so on.

The IEM data set includes 49 markets, 41

worldwide elections, and 13 countries. Several results stand out: the closing market prices, produced by a nonrepresentative sample of traders, show lower average absolute forecasting error (1.5 percent) than the representative exit poll samples (1.9 percent); in the subset of 16 national elections, the market outperforms the polls in 9 of 15 cases; in the course of several months preceding the election outcome, the market predictions are consistently much less volatile than the polls; generally, larger and more active markets predict better than smaller, thinner markets; surveys of the market traders show that their share holdings are biased in favor of the candidates they themselves prefer.

In view of this last result why do markets outperform the polls? Forsythe et al. (1992) argue that it's their marginal trader hypothesis. Those who are active in price "setting," that is, in entering limit bids or asks, are found to be less subject to this bias, than those traders accepting (selling and buying "at market") the limit bids and asks. Polls record unmotivated, representative, average opinion. Markets record motivated marginal opinion that cannot be described as "representative." This analysis helps to provide a good mechanical, if not ultimate, understanding of how human interaction with the rules of a bid/ask CDA yield efficient predictions.<sup>30</sup>

<sup>30</sup> Other markets besides the IEM are known to have efficient information-aggregating properties. Pari-mutuel racetrack markets are an example where, interestingly, the environment is much like the IEM: the settlements occur at a well-defined end-state known to all agents, unlike stock market trading where expectations float continuously with no clear value revelation endpoint. "The racetrack betting market is surprisingly efficient. Market odds are remarkably good estimates of winning probabilities. This implies (*sic*) that racetrack bettors have considerable expertise, and that the markets should be taken seriously" (Thaler and William T. Ziemba, 1988, p. 169). It is surprising to behavioral economists because their methodology is restricted to looking for deviations from the standard model. What is unusual here is that in racetracks they have found reportable evidence for efficient outcomes. For those who follow the experimental economics, IEM and similar controlled-environment market studies, efficiency is not only commonplace (if not universal), it cannot be attributed to agents with "considerable expertise." The agents are mostly naive, although they get repeat interaction experience, which, from the evidence, clearly gives them expertise enough. But, as in the IEM and experimental markets, racetrack markets are not perfect: there are inefficiencies in the "place" and "show" options and the favorite-long-shot bias, with the

We have seen that markets economize on information, understanding, the number of agents, and individual rationality. Can they also economize on the need for external intervention to protect particular interests, if all are empowered by the trading institution to act in their individual interests?

### B. *Strategy-proofness: Theory and Behavior*

Preferences are private and unobservable, and institutions have to rely on the messages reported by agents, not their true preferences. This follows from the fact that no one mind has all the information known together by all those in the market. It is therefore possible for an agent to affect prices and outcomes in a market by strategically misreporting preferences. This prospect has motivated the literature seeking strategy-proof mechanisms: "An allocation mechanism is strategy-proof if every agent's utility-maximizing choice of what preferences to report depends only on his own preferences and not on his expectations concerning the preferences that other agents will report" (Mark Satterthwaite, 1987, p. 519). This requires each agent to have a dominant strategy to report true preferences, and has led to impossibility theorems establishing the nonexistence of such a mechanism under certain conditions.

In view of such negative theoretical results and the narrow conditions under which solutions have been investigated, it is important to ask what people actually do in experimental environments in which the experimenter induces preferences privately on individual subjects. We know what is impossible, but what is possible in more open-ended systems than are modeled by theory? Is it possible that when all are free to choose from a large space of strategies, ecologically rational strategies will emerge that immunize against strategic manipulation? Given that information is inherently

---

latter more pronounced in the last two races of the day. Various hypotheses have been offered to explain these inefficiencies, but more significant is that computer programs have been written to arbitrage (yielding returns of some 11 percent per bet), the place, show, and long-shot inefficiencies. (It is my understanding that good profits have been accumulated on these programs, so far without neutralizing the arbitrage opportunities—let the good times roll!)

dispersed, has society evolved institutions in which forms of behavior arise that result in practical if not universal solutions to the problem of strategy-proofness?

The double auction is a well-known example yielding CE in a wide range of economic environments including small numbers. Are there other examples, and if there are, what are the strategic behavioral mechanisms that people adopt to achieve strategy-proofness?

One example is the sealed-bid-offer auction: in each contract period the submitted bids are ordered from highest to lowest, the offers (asks) from lowest to highest, with the intersection (cross) determining the uniform clearing price and volume exchanged (see Timothy Cason and Friedman, 1993; Friedman, 1993; and Wilson, 1993). Also see Smith et al. (1982) for comparative studies of different versions of the sealed-bid-offer mechanism and the continuous double auction.

In experiments with stationary supply and demand, initially both buyers and sellers greatly underreveal their true individual willingness to buy or sell. Volume is very low (10–15 percent of optimal), the market is inefficient and each agent can see that at the initial clearing price they are leaving money on the table. In repeat play they increase revelation, but mostly of units near the last period's clearing price. As volume increases and the clearing price closes in on the CE, the realized inverse demand and supply become very flat near the true clearing price with many tied or nearly tied bids and asks that exceed the capacity of any single buyer or seller. At this steady state, and given this behavior, if anyone withholds purchases or sales she is denied an allocation as other more competitively traded units substitute for hers. This results in a "behavioral strategy-proof equilibrium." Such is the power of motivated, privately informed agents in trial-and-error repeat interaction.

These experimental results make it plain that the theoretical condition for a strategy-proof equilibrium—that each agent have a dominate strategy to reveal true willingness-to-pay or willingness-to-accept for all units, and not just units near the margin—is much too strong. The above description from blind two-sided auctions, however, also shows that there is a social cost to the achievement of a strategy-proof equilibrium: blind two-sided auctions converge

more slowly to the competitive equilibrium than continuous double auctions, and upon converging, may not be quite as efficient if agents occasionally attempt manipulation, are disciplined, and return to the full exchange volume.

A second example is the uniform price double auction (UPDA), a real-time continuous feedback mechanism clearing all trades at a single price in each trading period. This is a "designer market" invented by experimentalists who asked, "Can we combine the continuous information feedback advantages of the double auction with the uniform price (zero within-period volatility) advantages of the sealed-bid-offer auction?" As we have seen above, with blind bidding several repeat interactions are required to reach optimality, with many lost trades in the process. Can we accelerate the price discovery process by continuously feeding back information on the tentative state of the market, and allowing bids (asks) to be adjusted within each period?

This institution is made possible by high-speed computer and communication technology. It comes in several flavors, or variations on the rules. In all versions at each time,  $t \leq T =$  time market is "called" (closed), the tentative clearing price,  $p_t$ , is displayed and each agent knows the acceptance state of all her bids (asks). This allows bids and asks to be adjusted in real time. See the chapter by McCabe et al. (1993, pp. 311–16) for a report of 49 UPDA experiments comparing these different versions with the continuous double auction. UPDA exhibits even more underrevelation of demand and supply than the blind two-sided auction discussed above, but efficiency tends to be much higher, especially in the first periods, and, in one form (endogenous close, open book, the "other side" rule with conditional time priority), exceeds that of the continuous double auction.

Experiments using UPDA in a randomly fluctuating supply and demand environment routinely exhibit efficiencies of 95–100 percent, sometimes with as little as 5–10 percent of the available surplus revealed. This is shown in Table 1 for summary data from UPDA experiment up43. Most agents enter bids (asks) equal to or near the clearing price as it is continuously displayed in real time. It is of course true, hypothetically, that if all agents reveal their true demand or supply with the exception of one intra-marginal buyer or seller, then that agent

TABLE 1—SUMMARY OF RESULTS: UPDA EXPERIMENT  
UP 43; 5, 5

	Pe	Qe	Pr	Qr	Eff%	Rev%
1	295	18	300	16	91%	22%
2	405	18	400	18	100%	7%
3	545	18	540	18	100%	14%
4	460	18	448	18	92%	14%
5	360	18	350	18	100%	9%
6	500	18	500	18	98%	12%
7	260	18	250	17	96%	26%
8	565	18	553	15	92%	28%
9	300	18	300	18	100%	28%
10	610	18	610	18	100%	33%
11	365	18	350	15	85%	88%
12	550	18	558	15	88%	55%
13	450	18	450	18	100%	31%
14	410	18	410	18	100%	5%
15	485	18	484	19	89%	39%
			$\mu = 17.3$		95%	27%
			$\sigma = 1.3$		5	21

Notes: (Pe, Qe) = equilibrium price and quantity. (Pr, Qr) = realized price and quantity. Eff% = efficiency, % max surplus. Rev% = % of surplus revealed.

can manipulate the price to his or her advantage. But this parable is irrelevant. The relevant question is what behavior is manifest when every agent has the potential for manipulating the price. Without knowledge or understanding of the whole, and without design or intention, the participants use the rules at their disposal to achieve three properties observed by the experimenter: (1) high efficiency, (2) maximum individual profit given the behavior of all other agents, and (3) protection from manipulation by their protagonists.<sup>31</sup> This ecological result illustrates the perceptive insight of Hayek (1988, pp. 19–20). “Rules alone can unite an extended

<sup>31</sup> Space prevents me from dealing fully with the many important issues raised when a subset of agents have asymmetric advance information on product quality or value characteristics. The analysis shows that such conditions generate market failure or inefficiency. Some of these problems, however, arise because the analysis is inadequate in examining both sides of the market, and the implications of the information content of prices. Experiments have established that constructivist inefficiency is often alleviated by one of several ecologically rational response mechanisms: competition among sellers for reputations, quality (brand) signaling, product warranties, and the aggregation of private asymmetric information into public price patterns that self-correct the alleged problems. See, e.g., Plott and Louis Wilde (1982); Plott and Sunder (1982, 1988); Miller and Plott (1985); Camerer and Keith Weigelt (1988).

order ... . Neither all ends pursued, nor all means used, are known or need be known to anybody, in order for them to be taken account of within a spontaneous order. Such an order forms of itself ... .”

### C. Gresham's Law: *If It Isn't Cournot-Nash, Why Is It a Law?*

In this section I have given many examples of institutions in which the CE theory of markets predicts their observed behavior. Do we have contrary examples? Yes. Gresham's Law: bad money drives out good. This “law,” while sometimes claimed to be an observed phenomena in countries all over the world, is not a Cournot-Nash equilibrium.<sup>32</sup> If currencies A and B are both available, A having an intrinsic worth while B is worthless fiat money, then the theory predicts that A will drive out B. This is because each agent believes other agents are rational, and will accept only A in exchange. Each agent will therefore avoid getting stuck with the inferior B by accepting only A, which becomes the dominant circulating medium of exchange, while B is “horded.” Experiments have confirmed that if both types of money are initially available, subjects use only the superior currency (an interest-bearing consol) as a medium of exchange. But in treatments in which subjects first experience a history of using fiat money, it being the only medium of exchange available, and then the consol is introduced, subjects continue trading with the fiat money, hoarding the interest-bearing consol (Gabriele Camera et al., 2003). This is entirely rational if each agent believes others will accept the fiat money in exchange and this belief is supported by experience. Think of Gresham's Law as a belief equilibrium in which theory alone is unable to predict when it might occur (Ledyard, 1986).

Complementing these results, another experimental study shows that when fiat money is the only currency, it will be used even under the

<sup>32</sup> Hayek (1967, p. 318) notes that Gresham's Law is not due to Gresham nor is it a “law” in the theoretical sense, and “... as a mere empirical rule is practically worthless.” In the 1920's when people started using dollars and other hard currencies in substitution for the depreciating mark, the claim emerged that Gresham's Law was wrong—that it was the other way around.

condition that it is abandoned and replaced with a new fiat money issue at the end of a finite horizon. In this study the real economy is found to suffer some loss in efficiency relative to the use of “backed” (commodity) money, but the economy does not collapse even in short horizon treatments. Collapse in real sector efficiency is observed only when a “government” sector prints fiat money to purchase real goods from the private sector. Moreover, additional experimental tests show that the collapse cannot be due to the resulting inflation, but to interference with the real price discovery of markets when some agents are able to crowd out private real purchases with printing press money<sup>33</sup> (Deck et al., 2001).

#### D. Psychology and Markets

Psychologists and “behavioral economists” who study decision behavior almost uniformly report results contrary to rational theory (Robin Hogarth and Melvin Reder, 1987). It was not always so,<sup>34</sup> but the focus on “anomalies,” beginning in the 1970’s, converted the emerging discovery enterprise into a search for contradictions between reports of behavior and the caricatures<sup>35</sup> of mainstream theory that constitute much of its core. Psychologists, to their credit,

<sup>33</sup> This is demonstrated by comparison experiments in which there are no government agents, but fiat money is inflated each period by the average rate that is observed in those experiments with government agents present.

<sup>34</sup> “Prior to 1970 or so, most researchers in judgment and decision-making believed that people are pretty good decision-makers. ... Since then, however, opinion has taken a decided turn for the worse, though the decline was not in any sense demanded by experimental results. Subjects did not suddenly become any less adept at experimental tasks nor did experimentalists begin to grade their performance against a tougher standard. Instead, researchers began selectively to emphasize some results at the expense of others.” “The view that people are irrational is real in the sense that people hold it to be true. But the reality is mostly in the rhetoric” (Lola Lopes, 1991, pp. 66, 80).

<sup>35</sup> I say “caricatures” because economics has long offered much in the way of theoretical exceptions to the core neoclassical model of self-interested market competition: externalities in choice, public good effects, and “anomalies” in choice under uncertainty requiring explanation (Friedman and L. J. Savage, 1948; Harry Markowitz, 1952). But it is the neoclassical assumption of self-interested agents that has been the most productive of theoretical results and therefore is a prominent and easy target of criticism.

have maintained an intensive program examining the behavioral nature of these contradictions to the classical model. For example, Sidney Siegel (1959) and Lawrence E. Fouraker and Siegel (1963) reported both confirmations and contradictions, and used the pattern to propose improved models. Similarly, in prospect theory Kahneman and Tversky (1979) have proposed modifications in both the utility and probability weighting functions of standard expected utility theory.<sup>36</sup> Research strategies that focus on the study of errors, however, can distort professional beliefs, to say nothing of popular representations, if the primary emphasis is on the failures, to the exclusion of the predictive successes, of the theory.<sup>37</sup>

#### E. Psychology, Economics, and the Two Kinds of Rationality

Curiously, the image of economists and psychologists as protagonists obscures their underlying agreement on foundations. Both rely upon constructivism: (1) to the extent that markets are

<sup>36</sup> Their most important contributions in prospect theory were in empirical tests demonstrating the relevance of two ideas suggested originally by Markowitz (1952): the idea that the theory applies to changes in wealth (income) relative to the individual’s current asset state, and that people are risk preferring in losses and risk averse in gains. This much is consistent with standard expected utility theory, which requires only that the prizes of choice can be ordered, and therefore applies either to wealth or income. Which prizes the theory is best applied to has always seemed to me to be inherently a subject for empirical determination. If applied to wealth, the theory starts to infringe on preference theory over time, long recognized as especially difficult modeling terrain.

<sup>37</sup> As I see it experimental market economics and behavioral economics are in principle complementary. Experimental economists study market performance (rationality) given individual valuations, while cognitive psychologists study the valuations (rationality) of individuals. If the objects traded are prospects the appropriate valuations are their “cash values,” whether based on expected utility, prospect theory (Kahneman and Tversky, 1979), or some other representation. Thus Plott and Jonathan T. Uhl (1981) study experimental markets in which the items traded are gambles, and report convergence to a CE defined by demand and supply based on the expected values of the gambles. But the connective interface between rationality at the individual and at the market level and how institutions modulate the interface has not been well explored. Markets do their thing with whatever are the values—rational, irrational, or nonrational—that are provided by individuals.

rational<sup>38</sup> or irrational,<sup>39</sup> this derives directly and only from the rationality or irrationality of agents;<sup>40</sup> (2) individual rationality is a self-aware, calculating process of maximization;<sup>41</sup> (3) predominantly both are reluctant to allow that naive, unsophisticated agents can achieve socially optimal ends without comprehension of the whole, as well as their individual parts, implemented by deliberate action (there is no “magic,” and no room for the GS zero intelligence traders); (4) consequently, psychologists test the rationality of individual decisions largely by asking for subject responses to choice problems to discover how they “reason.” Rather than challenge this constructivist view, economists, subject to the identical vision (how do agents consciously think?), are critical of the question-response survey methods used in cognitive psychology: the stakes are zero or too low,<sup>42</sup> and the subjects are too unsophisticated, inexperienced, or untrained to allow a serious researcher to find out how “real agents really think.” Many psychologists appear to find irrationality everywhere, and many economists appear to see the findings as everywhere irrelevant. To these economists, how agents think indeed exhausts the core of empirical econom-

ics; psychologists merely “fail” to properly implement their investigation of this core.<sup>43</sup>

In point of fact, opinion surveys can provide important insights: sometimes survey findings can be tested more rigorously with reward-motivated choices in the laboratory or the field and are found to have predictive content (e.g., the asymmetry between losses and gains in wealth). Sometimes what people actually do completely contradicts what they say, and sometimes you cannot find out by asking because the agents themselves do not know what they will do or are doing. For example:

- Comparisons of risk preferences under low and high monetary stakes have shown that actual reward levels have a statistically significant effect on decision, but that the qualitative conclusions from hypothetical choice response surveys are not refuted by studies using very high stakes—the accumulated payoffs average three times subjects’ normal monthly living expenses (Steven J. Kachelmeier and Mohamed Shehata, 1992; also see Hans P. Binswanger, 1980, for similar findings).
- Consider the double auction in classroom demonstration experiments: in debriefings afterwards students deny that there is any kind of quantitative model that could predict their market price and exchange volume, or that they were able to maximize their profits; but a participant with an envelope containing the predictions provided in advance, opens it showing that this consensus is false. The dispersed private value/cost information is aggregated into prices that are at the equilibrium and each agent is maximizing his or her profit given the behavior of all others. Here there is indeed a kind of “magic,” but only, I think, in not being well understood or modeled at the game-theoretic level of individual choice.<sup>44</sup>

<sup>38</sup> For example, the double-auction markets discussed above.

<sup>39</sup> Experimental asset markets bubble and crash on the long path of experience to equilibrium (Smith et al., 1988; Porter and Smith, 1994). For a new study of subject experience and asset bubbles see Martin Dufwenberg et al. (2003).

<sup>40</sup> Thus, even a “... monopolist ... has to have a full general-equilibrium model of the economy” (Kenneth Arrow, 1987, p. 207). Also see footnote 30 above on racetrack market efficiency, and the inference that the bettors must therefore have considerable expertise. Thus, market rationality is automatically assumed to derive entirely from individual rationality.

<sup>41</sup> Here is a particularly clear statement of decision as rational constructivist action: “Incentives do not operate by magic: they work by focusing attention and by prolonged deliberation” (Tversky and Kahneman, 1987, p. 90).

<sup>42</sup> The use of cash or other reward medium in decision behavior experiments is listed by Ralph Hertwig and Andreas Ortmann (2001) as one of the key differences between psychology and economics experiments. The controversy over paying subjects, however, is rapidly being eroded as cognitive psychologists and experimental economists join with neurobiologists—including those who are informed on animal behavior models—and subjects are paid salient rewards (Gregor Thut et al., 1997; Hans C. Breiter et al., 2001; McCabe et al., 2001).

<sup>43</sup> Kahneman clearly does not see people as irrational except in the narrow context used in economic modeling based on dominant choice. In fact he describes his empirical findings contradicting the SSSM as having been easy, thanks to the implausibility to any psychologist of the SSSM. See the Nobel Foundation interview of the 2002 Nobel Laureates in economics at <http://www.nobel.se/economics/laureates/2002/kahneman-interview.html>.

<sup>44</sup> At the macro-market level, convergence, and cases of stable and unstable equilibrium, are well predicted by the classical Walrasian adjustment model, but the paths taken, including jumps across alternative unstable equilibria, are

Our bounded rationality as economic theorists is far more constraining on economic science, than the bounded rationality of privately informed agents is constraining on their ability to maximize the gains from exchange.

- In asset trading, participant survey responses reflect the disconnect between their information on fundamental value and their puzzling experience of a price bubble and crash generated on the long path to the rational expectations equilibrium (T. Schwartz and J. S. Ang, 1989).
- Opinion polls administered to the IEM traders show the same judgment biases that psychologists and political scientists find in public opinion polls, but these biases did not interfere with the market's ability to predict the popular vote outcomes (Forsythe et al., 1992).
- In preference reversal survey experiments subjects report many inconsistent choices: gamble A is preferred to B but a subject will sell A for less than B. Arbitraging the subjects' cash-motivated choices quickly reduces these inconsistencies (Yun Peng Chu and Ruey Ling Chu, 1990, p. 906), and it has been shown that the inconsistencies are unbiased random errors under some, but not all, conditions (James C. Cox and David M. Grether, 1996); also see Barry Soper and Gary Gigiolotti, 1993, where choice intransitivity is studied directly and the errors are found to be random.
- Kahneman et al. (1986; hereafter KKT) provide many examples in which respondents are asked to rate the fairness,<sup>45</sup> on a four-

point scale, of elementary business actions in competitive environments. In one case a hardware store raises the price of snow shovels from \$15 to \$20 after a snowstorm. Eighty-two percent of the respondents consider this action either unfair or very unfair. Franciosi et al. (1995, pp. 939–40) substitute the words “acceptable” for “fair” and “unacceptable” for “unfair”<sup>46</sup> and add one additional sentence to this KKT example: “The store does this to prevent a stock out for its regular customers since another store has raised its price to \$20.” Now only 32 percent rate the action unfavorably. This exercise suggests the possible sensitivity of survey results to emotive words and/or perceived “justification” in terms of impersonal market forces.

Note that it is in private information environments, where the market is aggregating information far beyond the reach of what each individual knows, and is able to comprehend, that the solicited opinions are so far off the mark. The surveys yield no useful understanding because the subjects have none to relate. In the complete information asset market, subjects are aware of its fundamental value structure, and come to have common expectations through an experiential process of repetition; i.e., initial common information is not sufficient to induce common expectations.<sup>47</sup> They play myopically and their expressed bafflement (“prices rise without cause”) reflects this myo-

---

not well predicted by the model. See the outstanding summary by Plott (2001). The disconnect with choice behavior is evident in the following: Walrasian dynamics makes ad hoc assumptions about price adjustments in response to excess demand saying nothing about the corresponding payoff motivation of the agents who drive the price changes. Walrasian dynamics is a story about the tâtonnement mechanism in which there are no disequilibrium trades, whereas Plott's (2001) summary is about continuous double-auction trading with a great many disequilibrium trades.

<sup>45</sup> The descriptor “fairness” has so many meanings in different contexts that I believe it is best to avoid the term entirely in experimental science except where it is explicitly modeled and the model tested in environments where subjects make decisions on the basis of the defining parameters of the model; then the descriptor “fair” and its ambiguity can be avoided altogether. This is the way it is used in the utilitarian definitions by Robert Franciosi et al. (1995), in Ernst Fehr and Klaus M. Schmidt (1999), and Bolton and Axel Ockenfels (2000). Of course it is appropriate to use the

---

descriptor if the purpose is to see how its instructional use might have an emotive affect on behavior. The emotive content of “fairness” is clear in the important work of Edward E. Zajac (1995), who has also examined the rhetoric of fairness arguments as self-interest serving in the Florida, 2000, election controversy (Zajac, 2002).

<sup>46</sup> KKT state that “... the phrase ‘it is fair,’ is simply an abbreviation for a substantial majority of the population studied thinks it is fair” (KKT, 1986, p. 201). But their main interest is in whether firm behavior is affected by community norms. Whether or not an action is “acceptable” would seem to be just as important in determining firm behavior as whether or not it is “fair.” If the two terms map into different attitudes, then there is inherent ambiguity in specifying the effect on firm behavior.

<sup>47</sup> This interpretation is consistent with asset-trading experiments using undergraduates, small businesspersons, corporation managers, and over-the-counter traders (Smith et al., 1988, Porter and Smith, 1994). Exceptions using inexperienced subjects, to my knowledge, have only been observed with advanced graduate students (McCabe and Smith, 2000).

pia. These comments suggest that much insight might be obtained from the systematic study of the conditions under which survey results are robustly informative and the conditions where they are not.

#### F. *Fairness: An Experimental Market Test*

In developing a descriptive theory<sup>48</sup> of the “reference transaction,” KKT state that what is considered “fair” may change: “Terms of exchange that are initially seen as unfair may in time acquire the status of a reference transaction” (KKT, 1991, p. 203). This paves the way for the adaptation of “fairness beliefs” to changes in the competitive equilibrium. Although the competitive model is the one that has static predictive content, its prediction is silent as to how long it will take to respond to a change in parameters. KKT’s arguments are not predictive, but they tell a story about why markets might be sluggish in responding to change. How good is their story?

Franciosi et al. (1995) state a preference model of optimal choice that allows for a utilitarian trade-off between own consumption and “fairness.” For example, the utility of two commodities  $(x, z)$  is given by:  $u(x, z) = z + ax - (b/2)x^2 - \alpha x[(\pi/\pi_0) - 1]$ , in which the seller’s profit,  $\pi$ , relative to a reference profit,  $\pi_0$ , appears as an “externality” in the buyer’s utility function. The usual maximization subject to an income constraint yields the inverse demand equation:  $p = a - bx - \alpha[(\pi/\pi_0) - 1]$ . Thus, for  $\alpha > 0$  any change in the environment that increases a firm’s profit relative to the reference profit has an external effect that lowers the buyer’s inverse demand for units  $x$ . If  $\alpha = 0$ ,

then we have the standard own-maximizing theory. Consequently, Franciosi et al. (1995) can test the hypothesis, never using the word “fairness,” that if subject buyers have a utilitarian concern for profits not being increased relative to a baseline then after a change from the baseline this should alter the observed equilibrium relative to the standard predicted equilibrium with no external effect,  $\alpha = 0$ . In a posted offer market giving KKT their best shot (sellers cannot see each other’s posted prices, and therefore cannot knowingly emulate or undercut each other’s prices), Franciosi et al. (1995) find that when  $\alpha = 0$  (implemented by either no disclosure, or by marginal cost-justifying disclosure) the market converges quickly to the new competitive equilibrium. When  $\alpha > 0$  (implemented by profit  $\pi$  and  $\pi_0$  disclosure) prices converge more slowly, but precisely, to the new equilibrium. Hence, under conditions most favorable to a “fairness” effect, the response dynamics is changed, but not the equilibrium as predicted by the standard competitive model. The discipline of the market swamps all but a transient “fairness” effect. If, realistically, sellers can see each others prices, I would predict a much smaller “fairness” effect, if any.

### III. Personal Social Exchange

One of the most intriguing discoveries of experimental economics is that (1) as we have seen, people invariably behave noncooperatively in small and large group “impersonal” market exchange institutions; (2) many (up to half in single play; over 90 percent in repeat play) cooperate in “personal” exchange (two-person extensive-form games); (3) yet in both economic environments all interactions are between anonymous players. In this section I shall attempt to summarize some of the most compelling evidence of cooperation in personal exchange—in the field as well as the laboratory—and review some of the test results designed to discriminate among the more prominent predictive hypotheses for modeling cooperative behavior. Whatever might be the most useful way to model and explain cooperation, unaided by market incentives, my working hypothesis throughout is that it is a product of an unknown mix of cultural and biological evolution, with the biology providing abstract function defining potential, and culture shaping the emergent

<sup>48</sup> This methodology is driven by the untenable belief that general theories can be derived directly from observations if you just have enough data (see Smith, 2002, and the references therein). “Perhaps the most important lesson learned from these studies is that the rules of fairness cannot be inferred either from conventional economic principles or from intuition and introspection. In the words of Sherlock Holmes in ‘The Adventure of the Copper Beaches’: ‘Data! Data! Data! I cannot make bricks without clay’” (KKT, 1986, pp. 115–16). Neither can a predictive theory of “fairness” be inferred from any amount of the KKT data. If N “fairness” rules are discovered by trial and error modifications in the survey questionnaires, you cannot reject the hypothesis that there is an N + 1 variation that will identify a new one. More data will not help, as the fairness concept is used here as a word that provides no effective means of modifying standard theory to correct for its predictive flaws.

forms that we observe. But to motivate the whole exercise in thought, I will begin with a discussion of some persistent cross-cultural social practices from business, law, anthropology, and American economic history.

How might a social rule (practice, norm) emerge, become a cultural fixture, and be widely emulated? I will use a parable to illustrate how a rule for “bargaining in good faith” might become established.

In bargaining over the exchange price between a buyer and seller, suppose the seller begins by announcing a selling price, the buyer responds with a lower buying price, the seller reduces his asking price, and so on. In this concessionary process it is considered bad form for the buyer (or seller), once having made a concession, to return to a lower (or higher) price. This violates a principle of “bargaining in good faith” (see Siegel and Fouraker, 1960, p. 20). How might this come about? One can suppose that those who fail to bargain in good faith would be less likely to be sought out by others for repeat transactions. Such behavior raises transactions cost by increasing the time it takes to complete a sale. Trading pairs would be expected to self-select, tending to isolate the more time-consuming bargainers, and it would take them longer to find those willing to tolerate the time cost of bargaining. Such practices—inherently economizing in this parable—might then become part of a cultural norm, powerful enough to be codified ultimately in contract law and in stock exchange rules. Proposition: in this manner collectives discover law in those rules that persist long enough to become entrenched practices. In this example the emergent rule reduces transaction cost, leaving open the classical question of how equilibrium can be characterized in bilateral bargaining.

#### A. *Spontaneous Order Without the Law*<sup>49</sup>

The early “law-givers” did not make the law they “gave”; they studied social traditions and

<sup>49</sup> Experimental studies have inquired as to whether emergent norms of cooperation and constructivist incentive schemes are substitutes, the latter crowding out the former. See Iris Bohnet et al. (2001) and Fehr and Simon Gächter (2002) for studies suggesting that they are substitutes (formal rules undermine informal cooperative norms), and Ser-

informal rules and gave voice to them, as God’s, or natural, law.<sup>50</sup> The common lawyer, Sir Edward Coke, championed seventeenth-century social norms as law commanding higher authority than the king. Remarkably, these forces prevailed, paving the way for the rule of law in England.<sup>51</sup> Similarly, the cattlemen’s associations, land clubs, and mining districts in the American West all fashioned their own rules for establishing property rights and enforcing them: the brand on the hindquarters of his calf was the cattlemen’s indelible ownership signature on his property, enforced by gunmen hired through his cattle club;<sup>52</sup> squatter’s rights were defended ably (possession is nine points of the law?) by the land clubs composed of those brave enough to settle wilderness lands in advance of veterans exercising their land script claims, and of set-

gio G. Lazzarini et al. (2002) for new results suggesting that they are complements—contracts facilitate the self-enforcement of relational elements beyond contractibility. I would hypothesize that both must be true: constructivist rules ultimately must pass fitness tests of ecological rationality. Formal rules that are incompatible with informal rules will be modified or eliminated; those that are compatible will persist. Hence, at any time slice in history, both must necessarily be observed across all socioeconomic experiments.

<sup>50</sup> “... ([A])ll early (my insertion: as in Sumar with the beginning of writing) ‘law-giving’ consisted in efforts to record and make known a law that was conceived as unalterably given. A ‘legislator’ might endeavor to purge the law of supposed corruptions, or to restore it to its pristine purity, but it was not thought that he could make new law. ... But if nobody had the power or intention to change the law ... this does not mean that law did not continue to develop” (Hayek, 1973, p. 81).

<sup>51</sup> What allowed the rule of “natural” or found law to prevail in England “... was the deeply entrenched tradition of a common law that was not conceived as the product of anyone’s will but rather as a barrier to all power, including that of the king—a tradition which Edward Coke was to defend against King James I and Francis Bacon, and which Matthew Hale at the end of the seventeenth century masterly restated in opposition to Thomas Hobbes” (Hayek, 1973, p. 85; also see pp. 167, 173–74).

<sup>52</sup> These voluntary private associations for sharing the cost of a common good—policing—were subsequently undermined by statehood, and the publicly financed local sheriff as the recognized monopoly law enforcement officer. This observation contradicts the myth that a central function of government is to “solve” the free-rider problem in the private provision of public goods. Here we have the reverse: the incentive of the cattlemen’s clubs was to free ride on the general taxpayer, assigning the sheriff the task of enforcing property rights in cattle. The same free-riding occurs with school busing programs, and in publicly provided education itself in which government financing need not require government provision.

tlers under the Homestead Act; mining claims were defined, established, and defended by the guns of the mining clubbers, whose rules were later to become part of public mining law (Terry L. Anderson and Peter J. Hill, 1975; John Umbeck, 1977). For over a century, the Maine lobstermen have established rights, used threats, then force, to defend exclusive individual lobster-fishing territories in the ocean (James Acheson, 1975). Eskimo polar bear hunting teams awarded the upper half of the bear's skin (prized for its long mane hairs used to line women's boots) to that person who first fixed his spear in the prey (Peter Freuchen, 1961). Extant hunter-gatherers have evolved sharing customs for the products of communal hunting and gathering. For example, the Ache of Eastern Paraguay share the volatile products of the hunt widely within the tribe, while the low variance products of gathering are shared only within the nuclear family (Hillard Kaplan and Kim Hill, 1985; Kristen Hawkes, 1991).

### B. *Ellickson Out-Coases Coase*

Using the rancher/farmer parable, Ronald H. Coase (1960) argued that if there were no costs of transacting, then theoretically efficiency could not depend on who was liable for damages to crops caused by stray animals. Legal liability gives the rancher an incentive to employ cost-efficient measures to control straying cattle. But if she were not liable, then in a world of zero transactions cost, victims would be led in their own interest to negotiate a settlement paying the rancher to undertake the same efficient control measures induced by legal liability. In so doing, trespass victims save the cost of crop damage, assumed to be more than the cost of cattle control—otherwise it is inefficient to control them. The externality is internalized by market negotiation incentives. Curiously, the Coase Theorem—that in the absence of transactions cost efficiency does not depend upon the locus of liability—was controversial. It was clearly intended as a kindly spoof of oversimplified theories that, in particular, ignored transactions cost.<sup>53</sup> The real problem, addressed

brilliantly by Coase, was to deal with the question of efficient liability rules in a world of significant transactions cost. He then proceeded to use the transactions cost framework to examine the problem of social cost in a variety of legal precedents and cases.<sup>54</sup>

In the beginning Shasta County California was governed by “open range” law, meaning that in principle ranchers are not legally liable for damages resulting from their cattle accidentally trespassing on unfenced land. Then, in 1945 a California law authorized the Shasta County Board of Supervisors to substitute a “closed range” ordinance in subregions of the county. Dozens of conversions have occurred since this enabling law. Under a closed range law the rancher is strictly liable—even if not negligent—for damage caused by his livestock. Robert C. Ellickson (1991), out-Coased Coase by, in effect, asking, “Given that this county applies the polar legal rules used in Coase’s illustration, how do neighbors in Shasta County actually handle the problem of stray cattle?” The answer: “Neighbors in fact are strongly inclined to cooperate, but they achieve cooperative outcomes not by bargaining from legally established entitlements,<sup>55</sup> as the parable supposes, but rather developing and enforcing adaptive norms of neighborliness that trump formal legal arrangements. Although the route chosen is not the one that the parable anticipates, the end reached is exactly the one that Coase predicted: coordination to mutual advantage without supervision by the state”<sup>56</sup> (Ellickson,

---

Roger B. Myerson, 1991, p. 506). These cases may limit extensions of the Coase Theorem, but do not, I think, detract from its essential message that the locus of liability was irrelevant.

<sup>54</sup> Coase (1974) also noticed that the lighthouse was frequently cited by theorists as an example of a “pure” public good. As was his style (to confront the casual parables of theory that finessed certain costs by fiat), his response in effect was, “Well, let’s see what people have done who actually operate lighthouses, or who use the services of lighthouses.” It turned out that early lighthouses were private enterprise, not government, solutions to a public good problem, and the alleged inevitability of free-riding was solved by the owner who contracted with port authorities to collect lighthouse fees when ships arrived portside to load or unload cargo.

<sup>55</sup> These are the outside options or threat points in game theory.

<sup>56</sup> The same results emerge in laboratory experiments reported by Hoffman and Matthew L. Spitzer (1985).

<sup>53</sup> Later game-theoretic formulations have allowed that with two or more alternatives there may exist “standoff equilibria” that stall agreement in Coase bargaining (see

1991, p. 4). Thus, Shasta County citizens, including judges, attorneys, and insurance adjusters, do not have full working knowledge of formal local trespass law.<sup>57</sup> Citizens notify owners and help catch the trespassing animal; use mental accounting (reciprocity) to settle debts, e.g., a rancher, whose cattle have strayed may tell the victim to come down and take some hay, or if your goat eats my tomato plants, you offer to help me replant them; use negative gossip, complain to officials, submit informal claims for money (but not through a lawyer) to punish deviant neighbors; rarely use lawyers to seek monetary compensation; share the building of fences, most often by a rule of proportionality—you pay more if you have more animals than your neighbor; ignore fence law as irrelevant; and do not change fence obligations with the planting of crops. Finally, contrary to the Coasian parable, the main cost of trespass is not from crop damage, but from highway collisions that kill animals and damage property.

### C. *Extensive Form Interactions Between Anonymously Paired Individuals*

Cooperation has also emerged in anonymous two-person extensive-form games in laboratory experiments. Although such behavior is contrary to rational prescriptions, it is not inconsistent with our examples of spontaneous order without externally imposed law.

Why do we study anonymous interactions in the laboratory? The model of nonrepeated game theory is about strangers without a history or a future (Robert W. Rosenthal, 1981), but anonymity has long been used in small group experiments to control for the unknown complexities of natural social intercourse (Siegel and Fouraker, 1960). It is well documented that face-to-face interaction swamps subtler procedural effects in yielding cooperative outcomes (Hoffman and Spitzer, 1985; Kagel and Roth, 1995). But more important, I believe it is this condition that provides the greatest scope for exploring the human instinct for social exchange, and how it is affected by context, re-

<sup>57</sup> Under open range the animal owner is liable for intentional trespass, trespass of a lawful fence, and trespass by goats, whatever the circumstances, suggesting the hypothesis that goat behavior had long been recognized in pastoral norms and now captured in codified law.

ward, and procedural conditions that vary elements of social distance. Again, studying what is not helps us to understand what is.

### D. *Perception and the Internal Order of the Mind: Why Context Matters*

Two decision tasks, represented by the same abstract game tree, may lead to different responses because they occur in different contexts. Why? The answer may be found in the process by which we perceive the external world. Hayek (1952)<sup>58</sup> was a pioneer in developing a theory of perception, which anticipated recent contributions to the neuroscience of perception. It is natural for our minds to suppose that experience is formed from the receipt of sensory impulses that reflect unchanging attributes of external objects in the environment. Instead, Hayek proposed that our current perception results from a relationship between external impulses and our past experience of similar conditions. Categories formed in the mind are based on the relative frequency with which current and past perceptions coincide. Memory consists of external stimuli that have been modified by processing systems whose organization is conditioned by past experience<sup>59</sup> (Hayek, 1952, pp. 64, 165). There is a “constant dynamic interaction between perception and memory, which explains the ... identity of processing and representational networks of the cortex that modern evidence indicates.” “Although devoid of mathematical elaboration, Hayek’s model clearly contains most of the elements of those later network models of associative memory ...” (Joaquin M. Fuster, 1999, pp. 88–89).

Hayek’s model captures the idea that, in the internal order of the mind, perception is self-organized: abstract function combines with experience to determine network connectivity and expansion.<sup>60</sup> Loss can occur either from lack of

<sup>58</sup> The *Sensory Order* was not published until 1952 when Hayek revised a manuscript, originally written in the 1920’s, entitled in English translation, “Contributions to a Theory of How Consciousness Develops” (noted in correspondence to me by Bruce Caldwell).

<sup>59</sup> The interdependence between perception and memory is revealed by the different descriptions of the same event by two eyewitnesses (Gazzaniga et al., 1998, pp. 484–86).

<sup>60</sup> Built into your brain is the maintained hypothesis that the world around you is stationary. Look at the wall and

function or the stimulus of developmental experience. Block or distort sensory input, and function is impaired; impair function by brain lesions or inherited deficiency, and development is compromised.

This model is consistent with the hypothesis that the mind is organized by interactive modules (circuits) that are specialized for vision, for language learning, for socialization, and a host of other functions (see Leda Cosmides and John Tooby, 1992; Pinker, 1994). In this view, mind is the unconscious product of coevolution between the biological and cultural development of our brains that distinguished us from other primates. It was what made reason possible. Our folk predilection for believing in the “blank slate” concept of mind (Pinker, 2002) makes plain that this interpretation of mind is just as consonant with our direct experience as was once the idea that the earth is flat, or that witches had to be destroyed. In each case to escape from the folk perception requires the falsifying indirect evidence, based on reason, to become part of our “felt” experience. Constructivist rationality then becomes ecologically rational.

### E. *Experimental Procedures*

The experiments I will report will show how social context can be important in the interactive decision behavior we observe. This possibility follows from the autobiographical character of memory and the manner in which past encoded experience interacts with current sensory input in creating memory. I will be reporting the results of decision-making in single play, two-person, sequential-move game trees. Subject instructions do not use technical and role-

suggestive words like “game,” “play,” “players,” “opponent,” and “partner” (except where variations on the instructions are used as systematic treatments to identify their effect);<sup>61</sup> rather, reference is made to the “decision tree,” “decision maker 1” (DM1) or 2 (DM2), and “your counterpart,” etc. The purpose is to provide a baseline context, which avoids emotive words that might trigger unintended meanings by the experimenter.<sup>62</sup> I do not mean that the baseline is “neutral,” a concept that is not clearly definable, given that context effects can depend on autobiographical experience. The effect of instructional variation on decision is an empirical matter and any particular set of instructions must always be considered a treatment unless the observations are shown to be robust to changes in the instructions. All observations must be seen as a joint product of experimental procedures and the theoretical hypotheses, implemented by particular parameters that it is our intention to test. This is not unique to laboratory observations, but a characteristic also of field observations, and the whole of science (see Smith, 2002, for examples from physics, astronomy, and experimental economics). It is therefore important to understand how procedures as well as different parameterizations (games, payoffs) affect behavior.

Subjects are recruited in advance for an economics experiment. Upon arrival at the appointed time they register, receive a show-up fee, and are assigned to a private computer terminal in a large room with 40 stations. Commonly there are 11 other people, well spaced throughout the room, in the experiments reported below. After everyone has arrived, each person logs into the experiment, reads through the instructions for the experiment, responds to instructional questions, and learns that he or she is matched anonymously with another person in the room, whose identity will never be known,

---

move your eyes back and forth with head still. The wall does not move. Now press your eyeball with your finger through the eyelid from the side. The wall moves as you jiggle your eyeball. Why the difference? When you flex the eye muscles and move your eyes back and forth, a copy of the signal goes to the occipital cortex to offset apparent movement of the wall so that the net perception is that of a stationary wall. This stabilizing self-ordered system for seeing also makes you vulnerable to optical illusions of motion. Moving your eyes back and forth between the tunnel gate and your airplane as it docks, you ambiguously “sense” that either the gate or the plane, or both, is in motion. The ambiguity is resolved only when the gate, or plane, stops.

<sup>61</sup> See Terence Burnham et al. (2000), discussed below, for a study comparing the effect of using “partner” and “opponent” in a trust game.

<sup>62</sup> It is not meaningful or helpful to talk about “experimenter effects.” There are instructional and procedural effects, including the presence or absence of an experimenter, what he/she knows or does not know (as in double blind behavioral experiments), and what he/she does or does not do. All of the elementary operations used to implement an experiment are treatments that may or may not have a significant effect on observed outcomes.

and vice versa. This does not mean that a subject knows nothing about their matched counterpart. For example, it may appear evident that he or she is another “like” person, such as an undergraduate, or an industry executive with whom one may feel more-or-less an in-group identity. Obviously, each person imports into the experiment a host of different past experiences and impressions that are likely to be associated with the current experiment.

#### F. *The Context of Decision: The Ultimatum Game Example*

Consider the ultimatum game, a two-stage, two-person game with the following abstract form: for each pair the experimenter makes a fixed sum of money,  $m$ , available (e.g.,  $m$  will be 10 one-dollar bills, or 10 ten-dollar bills); Player 1 moves first offering  $0 \leq x \leq m$  units of the money to Player 2, Player 1 retaining  $m - x$ ; Player 2 then responds by either accepting the offer, in which case Player 1 is paid  $m - x$ , and Player 2 is paid  $x$ , or rejecting the offer, in which case each player receives nothing.

Below I report ultimatum results from four different instructional/procedural treatments (contexts) that have the same underlying abstract game structure. In each case imagine that you are Player 1. See Hoffman et al. (1994; hereafter HMSS) for instructional details, and for references to the literature and the origins of the ultimatum game.

*Divide \$10.*—You and your counterpart have been provisionally allocated \$10, and randomly assigned to positions. Your task as Player 1 is to divide the \$10 by filling out a form that will then go to your counterpart who will accept or reject it.

*Contest Entitlement.*—The 12 people in the room each answer the same 10 questions on a general knowledge quiz. Your score is the number of questions answered correctly; ties are broken in favor of the person who first finished the quiz. The scores are ranked from 1 (highest) through 12 (lowest). Those ranked 1–6 are informed that they have *earned* the right to be Player 1, the other six will be Players 2.

*Exchange.*—Player 1 is a seller, and Player 2 is a buyer. A table lists the buyer and seller

profit for each price \$0, \$1, \$2, ... , \$10 charged by the seller, and the buyer chooses to buy or not buy. The profit of the seller is the price chosen; the profit of the buyer is ( $\$10 - \text{price}$ ). Each receives nothing if the buyer refuses to buy.

*Contest/Exchange.*—This treatment combines Contest with Exchange; i.e., the sellers and buyers in Exchange are selected by the contest scoring procedure. In one version the total amount is 10 one-dollar bills, and in the second it is 10 ten-dollar bills.

Whatever the context there is a game-theoretic concept of equilibrium (subgame perfect) that yields the same prediction in all four treatments (Reinhard Selten, 1975): Player 1 offers the minimum unit of account, \$1 (\$10) if  $m = \$10$  (\$100), and Player 2 accepts the offer. This follows from the assumption that each player is self-interested in the narrow sense of always choosing the largest of two immediate payoffs for herself; that this condition is common knowledge for the two players; and that Player 1 applies backward induction to the decision problem faced by Player 2, conditional on Player 1's offer. Thus Player 1 reasons that any positive payoff is better than zero for Player 2 and therefore, Player 1 need only offer  $x = \$1$  (\$10).

One difficulty with this analysis is that, depending on context, the interaction may be interpreted as a social exchange between the two anonymously matched players who in day-to-day experience read intentions into the actions of others (S. Baron-Cohen, 1995). Suppose the situation is perceived as a social contract as follows: if Player 2 has an entitlement to more than the minimum unit of account, then an offer of less than the perceived entitlement (say, only \$1, or even \$2–\$3) may be rejected by some Players 2. Player 1, introspectively anticipating this possible mental state of Player 2, might then offer \$4 or \$5 to insure acceptance of his offer. Alternatively, Player 1 might enjoy (get utility from) giving money to his counterpart. The point is simply that there are alternative models to that of subgame perfection that predict choices in the ultimatum game, and these alternatives leave wide latitude for the possibility of context affecting the behavior of both players. Abstract game theory can embrace

TABLE 2—MEAN PERCENTAGE OFFERED BY TREATMENT IN ULTIMATUM GAMES<sup>a</sup>

Context	Measure	\$10 stakes			\$100 stakes		
		Divide \$10	Exchange	Exchange, strategic prompt	Divide \$100	Exchange	Exchange (graduate students) <sup>c</sup>
Random entitlement	Mean (percent)	43.7	37.1	41.7	44.1	NA	NA
	N	24	24	24	27	NA	NA
	(Percent rejected) <sup>b</sup>	(8.3)	(8.3)	(12.5)	(3.7)	NA	NA
Earned entitlement	Mean (percent)	36.2	30.8	39.6	NA	27.8	28.8
	N	24	24	24	NA	23	33
	(Percent rejected) <sup>b</sup>	(0)	(12.5)	(2.9)	NA	(21.7)	(21.2)

<sup>a</sup> Data from Hoffman et al. (1994; 1996a). See the references for the statistical significance of pairwise comparisons as discussed in the text.

<sup>b</sup> Refers to percentage of the N pairs in which the second player rejects the offer of the first.

<sup>c</sup> The graduate students were visiting participants in an introductory workshop in experimental economics. These are new data not previously reported.

these alternatives through the artifice of “types”—utilities, or beliefs states such as trust, trustworthiness, reciprocation, etc. Ultimately the predictive success of such models depends on relating task descriptions defining context to autobiographical characteristics of individuals that are then identified by types that in turn determine behavior. The point that needs emphasis is that it is easy to go from types (traditionally utility or beliefs about states) to game-theoretic choice; the hard part is to relate types to characteristics of the individual’s memory-sensory system. Given the directions of neuroscience and the learning from brain imaging, I do not think this is an impossible order.

Observe that in “Divide \$10” the original \$10 is allocated imprecisely to both players. Moreover, a common definition of the word “divide” (Webster) includes the separation of some divisible quantity into equal parts. Finally, random devices are recognized as a standard mechanism for “fair” (equal) treatment. Consequently, the instructions might be interpreted as suggesting that the experimenter is engaged in the “fair” treatment of the subjects cueing them to be “fair” to each other.

As an alternative, Contest deliberately introduces a pre-game procedure that requires Player 1 to “earn” the right to be the first mover. This may cue some insipient norm of just desserts based on the pre-game quiz.

In Exchange the ultimatum game is imbedded in the gains from exchange from a transaction between a buyer and a seller. In an exchange, both the buyer and the seller are made better off, and buyers in our culture may accept the right of a seller to move first by quoting a price.

Contest/Exchange combines the implicit property right norm of a seller with a mechanism for earning the property right.

Table 2 summarizes the results from two different studies of ultimatum game bargaining with stakes of either 10 one-dollar or 10 ten-dollar bills for each of N pairs of players, where N varies from 23 to 33 subject pairs.

1. Comparing Divide \$10 with Divide \$100 under the random entitlement we observe a trivial difference in the amount offered between the low stakes (43.7 percent) and the tenfold increase in the stakes (44.4 percent). Also, there is no significant difference in the percentage rate at which offers are rejected, 8.3 percent, and 3.7 percent, respectively.
2. When Exchange is combined with an earned entitlement the increase in stakes lowers the offer percentage from 30.8 percent for \$10 stakes to 27.8 percent for \$100 stakes, but this difference is within the normal range of sampling error using different groups of subjects and is not significant. Surprisingly,

however, this miniscule decline in the mean offer causes the rejection rate to go up from 12.5 percent to 21.7 percent. Three of four subject Players 1 offering \$10 are rejected, and one offer of \$30 is rejected in the game with \$100 stakes. As has been shown in trust/punishment games, this behavior is associated with a strong human propensity to incur personal cost to punish those who are perceived as cheaters, even under strict anonymity.

3. We note that comparing the Divide \$10/Random entitlement condition with the Exchange entitlement, the offer percentage declines from 43.7 percent to 37.1 percent, and comparing the former to the Earned entitlement the decline is from 43.7 percent to 36.2 percent, both reductions being statistically significant. Even more significant is the reduction from 43.7 percent to 30.8 percent when the Earned and Exchange entitlements are combined. Moreover, in all four of these comparisons the rejection rate is null or modest (0 to 12.5 percent).
4. The small proportion of the offers that were rejected, except when the stakes were \$100 in the Earned/Exchange context and the mean offers declined to a low of 27.8 percent, indicates that Players 1 read their counterparts well, and as the context is altered, normally offer a sufficient amount to avoid being rejected. The one exception shows clearly that pushing the edge, even if it seems justified by the higher stakes, may invite an escalation of rejections.

These data indicate that context is important in the ultimatum game: the percentage offered varies by over a third as we move from the highest (44 percent) to the lowest (28 percent) measured effect. Also see Hoffman et al. (2000). Like variation is reported in cross-cultural experiments: a comparison of two hunter-gather and five modern cultures reveals variation from a high of 48 percent (Los Angeles subjects) to a low of 26 percent (Machiguenga subjects from Peru) (Joseph Henrich, 2000). These comparisons used care in attempting to control for instructional differences across different languages, but this is inherently problematic, given the nature of perception, in that one cannot be sure that the instructions, translations, payoffs, or the procedures for handling the subjects, control adequately

for context across cultures. In each culture one needs to vary the instructions/procedures and observe the sampling distribution of outcomes, then compare the sample distributions across cultures.

These instructional treatment effects call into question the extent to which one can define what is meant by “unbiased” instructions. If results are robust with respect to instructional changes, this can only be established empirically. Without such studies no claims can be made concerning the relative “neutrality” of instructions. The main lesson is that, because of the nature of perception and memory, context should matter, and in the ultimatum game the variation of observed results with systematic instructional changes designed to alter context shows clearly that context can and does matter. Experimenters, subject to the same perception/memory variations, are likely to disagree as to what is “neutral.”

#### G. Dictator Games With and Without Gains from Exchange

The ultimatum game is converted into a dictator game by removing the right of the second mover to veto the offer of the first. Forsythe et al. (1994; hereafter FHSS) note that if the observed tendency toward equal split of the prize is due primarily to “fairness”—a social norm of just division—then it should be of little consequence if this right is eliminated. But if it is the prospect of rejection—however irrational—that tempers the amount offered by Player 1, then the outcomes should be materially affected by removing the right of rejection, which converts the ultimatum game into what is called the dictator game. Thus a significant reduction in the mean percent offered in the dictator game would be consistent with the second hypothesis, while no significant reduction would be consistent with the first. Comparing the results in Table 3, column 1 with those for Divide \$10, Random entitlement in Table 2, we see that the mean dictator offer is only 23.3 percent compared with the mean ultimatum offer of 43.7 percent. FHSS conclude that fairness alone cannot account for behavior in the ultimatum game. This is correct, but, equally of interest, why are dictators giving away nearly a quarter of their endowment? This research puzzle was picked up by HMSS who conjectured that such gener-

TABLE 3—DICTATOR GIVING: WITH AND WITHOUT GAINS FROM EXCHANGE AND SOCIAL HISTORY

Treatments	Standard dictator game giving		Double blind <sup>b</sup> dictator giving under gains from exchange <sup>c</sup>			
			Baseline		Social history	
Player role	Single Blind FHSS <sup>a</sup>	Double Blind 2 HMSS <sup>b</sup>	Sent (Player 1)	Returned (Player 2)	Sent (Player 1)	Returned (Player 2)
Mean percent given of total available	23.3	10.5	51.6	27.2 <sup>d</sup>	53.6	35.5 <sup>d</sup>
Mean percent given by top 50 percent givers	38.3	21.0	74.4	49.4	82.7	55.8

<sup>a</sup> Data from Forsythe et al. (1994), replicated by Hoffman et al. (1996b).

<sup>b</sup> Data from Hoffman et al. (1994), Double Blind 2.

<sup>c</sup> Data from Berg et al. (1995). Their procedures are different, but are nearest to those of Double Blind 2 in HMSS.

<sup>d</sup> Since the sender amount is tripled, if the receivers return an average of 33.3 percent, then the average amount returned will equal (pay back) the amount sent.

osity might be, at least in part, a consequence of the incompleteness of anonymity. In all the games prior to the HMSS study the members of each player pair were anonymous with respect to each other but not with respect to the experimenter who knew every person's decision. Hence, they introduced a "double blind" treatment category (two versions) in which the protocol made it transparent that no one, including the experimenter, could learn the decisions of any player. Data from the second version, Double Blind 2, are reported in Table 3. In this treatment mean dictator offers decline to only 10.5 percent. Consequently, context—in this case social connectedness or distance—has an important affect on dictator transfers.<sup>63</sup> These issues are explored more fully in Hoffman et al. (1996b), who vary social distance by varying the instructional and protocol parameters that define various versions of single- and double-blind dictator games. Also reported in Table 3 is the percent given by the top 50 percent of the most generous dictators: 38.3 percent for Single Blind and 21 percent for Double Blind.

Berg et al. (1995, hereafter BDM) modify the dictator game to introduce gains from "ex-

change."<sup>64</sup> Their investment trust two-stage dictator game also uses the Double Blind 2 protocol: dictators in room A send any portion of their \$10 (0 to \$10) to their random counterpart in room B. People in both rooms know that if \$x is sent by anyone, it is tripled, so that the counterpart receives \$3x. Thus, the most generous offer, \$10, yields a gain of \$30. The counterpart can then respond by sending any part (0 to \$3x) of the amount received back to his or her matched sender. Now an exchange with gains to both parties is possible, and BDM ask if this context is a significant treatment. Note that the analysis of the game is no different than the one-stage dictator game: by the principle of backward induction Player 1 can see that Player 2's interest is to keep all the money received, and therefore nothing should be sent. The fact that the sender's transfer will be tripled is irrelevant. But it is not irrelevant if both players see the interaction as an exchange based on trust by Player 1 and trustworthiness by Player 2.

In Table 3 sender Players 1 now give 51.6 percent when the transfer is tripled, compared with 23.3 percent when it is not. Furthermore, the top 50 percent of the givers send 74.4 percent of the money, up from 38.3 percent. This shows how the tripled pie shifts the distribution

<sup>63</sup> These double blind procedures and treatment effects have been replicated by two other investigations (Catherine C. Eckel and Philip J. Grossman, 1996, and Burnham, 1998). Bolton et al. (1998), using a different double blind procedure failed to replicate the results, suggesting that procedures matter and interact with the double blind condition.

<sup>64</sup> For a recent extension and replication of the BDM findings see Madan Pillutla et al. (2003). Also see Ortmann et al. (2000).

toward larger transfers by Players 1. But on average the senders do not quite break even: an average of 27.2 percent of the amount received by Players 2 is returned to Players 1 (break even would be 33.3 percent since  $x$  is tripled). In the social history treatment the instructions and protocol are the same as described above except that the second treatment group is shown the distribution of amounts transferred and returned for the first group. Comparing the social history with the baseline mean percent given and returned reveals the effect of being exposed to the decision data of the first group. Social history does not cause a reduction in transfers, which actually increases marginally from 51.6 percent to 53.6 percent. The average percent returned increases from 27.2 percent to 35.5 percent, just above the break-even level.

These results are not explicable by the canons of traditional game theory that assumes self-interested (in the sense of always choosing larger payoffs) types. By introducing gains from the investment by Player 1, who can only benefit if Player 2 perceives the process as an exchange calling for payment for services rendered, dictator giving more than doubles. And the effect of social history does not precipitate a decline in investment nor in the return to Players 2—in fact both increase slightly. The same behaviors have been observed in chimpanzee and capuchin monkey communities (Frans B. M. deWaal, 1989, 1997). Should such trusting and trustworthy behaviors be diminished in human communities characterized by the maxim that “the rules of morality are not ... conclusions of (our) reason?”

#### H. *Trust Games*

Ultimatum and dictator games have been studied extensively, but are much too simple to allow an adequate understanding of some of the underlying behavior manifest in them. It is tempting to overinterpret them in terms of a mixed utility for own and other reward. The potential for greatly expanding what can be learned is illustrated in Table 3 where BDM extended the dictator game to a two-stage game with gains from voluntary exchange. We turn therefore to a somewhat richer class of two-person extensive-form trust games in which equilibrium play, cooperation, and the prospect

of defection can be studied in a richer parameter space than the ultimatum game.<sup>65</sup>

Figure 1 is a typical “trust” game tree.<sup>66</sup> Play starts at the top of the tree, node  $x_1$ , with Player 1 who can move right, which stops the game yielding the upper payoff to Player 1, \$10, and the lower payoff to Player 2, \$10, or move down in which case Player 2 chooses a move at node  $x_2$ . If Player 2’s move is right, Player 1 receives \$15, and Player 2, \$25. This is the cooperative (C) outcome. If, however, Player 2 moves down, the payoffs to 1 and 2 are, respectively, \$0 and \$40. This is the defection (D) outcome, in which Player 2 defects on Player 1’s offer to cooperate. The subgame-perfect equilibrium (SPE) is \$10 for each player. This follows because at node 1 Player 1 can apply backward induction by observing that if play reaches node  $x_2$ , Player 2’s dominant choice is to defect. Seeing that this is the case, Player 1’s dominant choice is to move right at the top of the tree, yielding the SPE outcome.

These game-theoretic assumptions are very strong. As we see from the above discussion, however, they have the dubious merit of allowing “unambiguous” predictions to be made about behavior.<sup>67</sup> We particularly want to note that if every player is exactly like every other player, and is strictly self-interested, there is no room for “mind reading,” or inferring intentions from actions, and no room for more sophisticated and subtle action in the self-interest.

To illustrate, suppose that you have been through the standard economics course in game

<sup>65</sup> Space does not permit examining also the effect of being able to punish defection. See McCabe et al. (1996) for a more complete report of trust games with and without punishment of defection and with a wide variety of matching protocols.

<sup>66</sup> As indicated above, the word “trust” never appears in the instructions. Of interest, however, is that the subjects use this word when you ask them open-ended questions about their analysis and perceptions of the game. “Its all a question of whether you can trust your partner.” Neither do we use the word “partner.”

<sup>67</sup> Except see Smith (2002), wherein it is shown that if, in addition to the research hypothesis derived from game theory (e.g., Cournot-Nash or SPE), there is one auxiliary hypothesis (e.g., payoffs are adequate, types have been accurately defined, or subjects are sophisticated), then either the theoretical hypothesis is not falsifiable, or it has no predictive content. The belief, however, persists that the predictions of game theory are sharp and unambiguous (see, e.g., Camerer et al., 2001).

theory and that you are in the position of Player 2 in Figure 1. Consequently, you expect Player 1 to move right at the top of the tree. He does not. He moves down, and it is your turn. Surely he did not move down because he prefers \$0 to \$10, or expects you to defect. He must think that you think that he wants you to choose C. Whatever else can he have in mind? Maybe he cannot do backward induction, or thinks you are not self-interested. So how are you going to respond? He is making it possible for you to increase your payoff by 150 percent, and his by 50 percent, compared with the SPE. He is not even asking for the larger share of the pie that his action has created! According to reciprocity theory, if you choose C, you will reciprocate his inferred intentions, and complete an exchange—exactly in the same way that you trade favors, services, and goods across time with your closer friends and associates in life (except for those who are victims of antisocial personality disorder, or sociopaths, and are unable to maintain social relations based on reciprocity),<sup>68</sup> also in the same way that you do not hesitate to leave a “tip” (“to insure promptness”?) for good service at a restaurant even in a foreign city. Without a conscious thought you often say, “I owe you one,” in response to an acquaintance’s favor. So you might choose C with hardly a thought, or, since he will never know your identity, upon closer reflection, you may think that it just makes no sense not to take the \$40. Although you are not a clinical sociopath, here is an opportunity to cut a corner and no one can know. As Player 1 in Figure 1 are you certain that you would want to play SPE?<sup>69</sup>

<sup>68</sup> “Sociopaths, who comprise only 3–4 percent of the male population and less than 1 percent of the female population, are thought to account for 20 percent of the United States prison population and between 33 percent and 80 percent of the population of chronic criminal offenders. Furthermore, whereas the “typical” U.S. burglar is estimated to have committed a median five crimes per year before being apprehended, chronic offenders—those most likely to be sociopaths—report committing upwards of 50 crimes per year and sometimes as many as two or three hundred. Collectively, these individuals are thought to account for over 50 percent of all crimes in the U.S.” (see Linda Mealy, 1995, p. 523, and pp. 587–99 for references and caveats; also David T. Lykken, 1995).

<sup>69</sup> This thought process may explain why, in data reported by Giorgio Coricelli et al. (2000) comparing faculty with undergraduate subjects, the faculty take much longer (and earn less money) than the undergraduates to decide

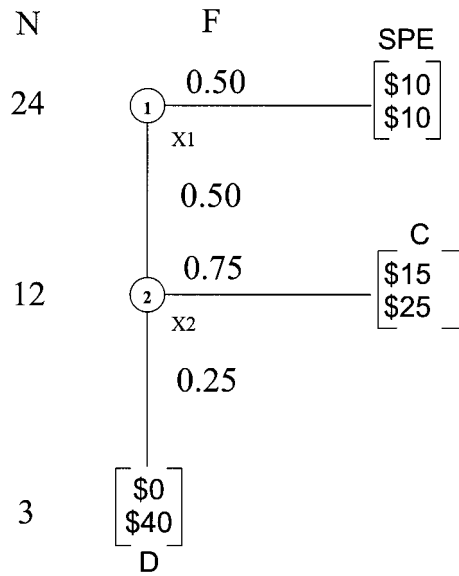

FIGURE 1. INVEST \$10 TRUST GAME: FREQUENCY OF PLAY  
 Notes: Abbreviations are as follows: N—number of subject pairs by node; F—frequency at which pairs move right or down; SPE—subgame-perfect equilibrium; C—cooperate; D—defect.

In regard to this reciprocity analysis of the game, we should note that the game in Figure 1 is a much reduced-form version of the BDM game: think of Player 1 as sending \$10, which becomes \$30; Players 2 can either split the \$30 equally with Player 1, giving the imputation C, or Player 2 can keep it all, yielding the D outcome. But there is another difference, one of context. In the experiment using Figure 1 the subjects play an abstract game, one that is not embedded in a BDM-type story about sending \$10 upstairs, which becomes \$30, and the receiver can either keep it all or split the gain made possible by the sender. But given the BDM outcomes reported above we should not be too surprised that some subject pairs might end at C.

The outcomes are shown in Figure 1 for 24 undergraduate subjects: 50 percent move down, and of these 75 percent “reciprocate.”

whether to offer cooperation, and whether to defect. Yet given knowledge of game theory, and knowing that one’s counterpart has the equivalent knowledge, what is there to think about?

*Why So Much Cooperation?*—My coauthors and I have interpreted the outcome C as due to reciprocity. But there are other interpretations; e.g., that the subjects are game-theoretically unsophisticated or have nonselfish preferences. The effect of subjects on outcomes is an empirical matter, and is most important, but cannot be pursued here in depth. It is essential to programs concerned with extending game theory to “player types.” Subject background diversity and resulting choice behavior can help inform the identification and classification of “types,” whether reciprocators, sophisticates, or utilitarian (see McCabe and Smith, 2001; McCabe et al., 2001).

*Is It the Subjects? Undergraduate’s Versus Graduates.*—In the above trust game nearly half the Players 1 forgo the sure thing, SPE, and three-quarters of the responses are cooperative. We have often heard such results dismissed as a consequence of using naive subjects. (This dismissal has the logical implication that the original theoretical hypothesis is either not falsifiable or has no predictive content. See footnote 67.) McCabe and Smith (2000) examined this explanation using advanced graduate students from the population, a sample of whom participated in the \$100 Exchange/Entitlement version of the ultimatum game reported in Table 2, showing almost identical results for graduate and undergraduate students. They used the trust game shown in Figure 1. For comparison, McCabe and Smith (2000) used the undergraduate data shown in Figure 2. In both groups 50 percent of Players 1 offer cooperation, while 75 percent of the undergraduate and 64 percent of the graduate student Players 2 reciprocate. However naive undergraduates are alleged to be, these tests suggest that graduate students with training in economic theory are capable of showing very similar behavior in this extensive-form game, and in the ultimatum game reported in Table 2.

*Is It Utility for Other?*—Bolton (1991), Rabin (1993), Fehr and Schmidt (1999), and Bolton and Ockenfels (2000) have proposed useful preference models of decision that aim at accounting for behavior in a variety of experiments, most particularly ultimatum and dictator games. The idea behind these models is that we can explain cooperation in bargaining games by

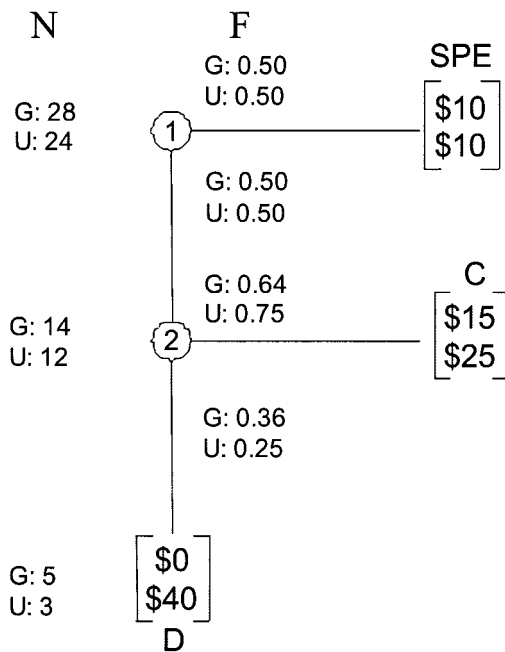

FIGURE 2. INVEST \$10 TRUST GAME  
COMPARING UNDERGRADUATES (U) AND GRADUATES (G)  
Note: For abbreviations, see Figure 1 notes.

saying that people have a taste for altruism or for “fair” outcomes (or a distaste for “unfair” outcomes), where fairness is understood as pay-off equity, as in Franciosi et al. (1995). The hypothesis is that subjects seek to maximize these adjusted utilities. It is only the intrinsic properties of outcomes that are assumed to drive behavior; what alternatives the players faced at a previous decision node are irrelevant. This means that intentions, as reflected in the move choices, are assumed to be superfluous in the interactions between the parties. The former approach identifies utility types. The latter identifies types who signal intentions, who are into reading move signals, and risk misidentifying reciprocity versus defection types. The important testable distinctions are that the former are immune to instructional procedures and to path dependency—the opportunity costs of forgone options; this constitutes the core of the research program of my coauthors and me. This program leads naturally to an understanding of its own limitations as well as that of the utilitarian program, i.e., both types may be needed.

Other-regarding preference models are unable to account for our previous data demonstrating that procedures and context variables matter. In the ultimatum game data reported above where the context is varied from “Divide \$10” to “Context/Exchange,” ostensibly the utilities to the participants are the same under each ultimatum condition. However, behavior varies dramatically. These models also cannot explain the results reported above in the single versus double blind protocol in dictator games, and the dramatic change in dictator behavior in the BDM investment trust game. Clearly, the behavior is much more variable than is expected from outcome-based utility models.

An altruistic utility interpretation of cooperation can be invoked in trust games like that in Figure 1: Player 2 may move down because her utility for reward is increasing in both own and other payoff. Figure 3 is a trust game that enables us to distinguish subjects who cooperate from motivations of altruism, and those whose cooperation derives from reciprocity in an exchange. The game starts at the top, node  $x_1$ , with Player 1 who can move right, which stops the game yielding the upper payoff to Player 1, \$7, and the lower payoff to Player 2, \$14, or move down in which case Player 2 chooses a move at node  $x_2$ . If the move is right, each player gets \$8. If Player 2 moves down, Player 1 can then move right at node  $x_3$  yielding \$10 for each, or down, yielding \$12 for Player 1 and \$6 for Player 2. The subgame-perfect equilibrium (SPE) is \$8 for each player. This follows because at node  $x_1$ , Player 1 can apply backward induction by observing that if play reaches node  $x_3$ , Player 1 will want to move down. But Player 2, also using backward induction will see that at node  $x_2$  he should move right. Since right at node  $x_2$  yields a higher payoff to Player 1, at node  $x_1$  Player 1 will conclude that he should move down. Hence, the SPE outcome would prevail by the logic of self-interested players who always choose dominant strategies, and apply the principle of backward induction.

If Player 1 has other-regarding preferences (altruism) and is willing to incur some cost to greatly increase the payoff to Player 2, Player 1 may move right at  $x_1$ . His payoff of \$7 is only one-eighth smaller than his payoff at the SPE, and yields \$14 for Player 2. Hence, at a cost of \$1 to himself, Player 1 can increase his coun-

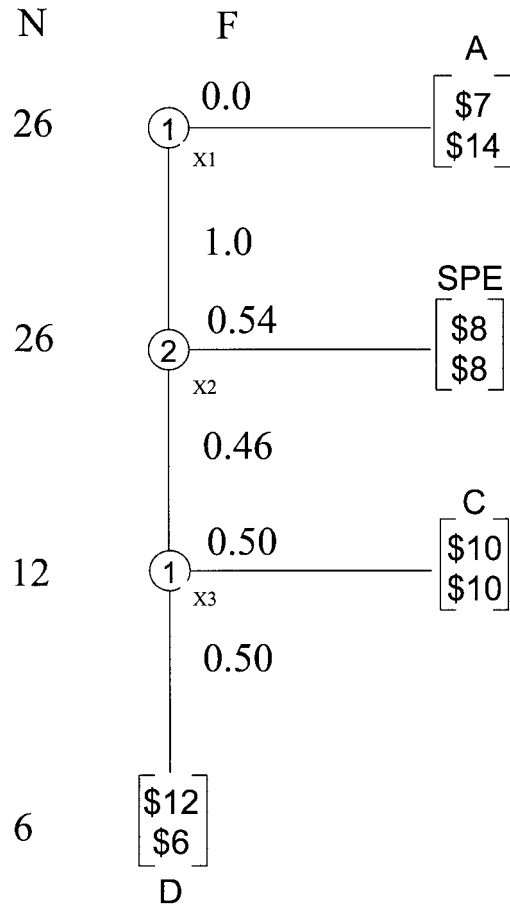

FIGURE 3. TRUST GAME WITH ALTRUISM: FREQUENCY OF PLAY

Note: For abbreviations, see Figure 1 notes.

terpart Player 2’s payoff by \$6. Player 1 need have only a modest preference for an increase in Player 2’s welfare to induce him to move right because of the 6 to 1 return for the other player over the cost to Player 1.

At  $x_2$ , Player 2 may move down signaling to Player 1 that such a move enables both to profit (gains from exchange), provided that at  $x_3$  Player 1 cooperates by reciprocating Player 2’s favor. Alternatively at  $x_3$  Player 1 can defect (D) on the offer to cooperate by choosing his dominate strategy, and move down.

The outcome frequencies for the trust game ( $N = 26$  pairs) are entered directly on the tree in Figure 3. The first result—overwhelmingly decisively—is that no Player 1 chooses the A

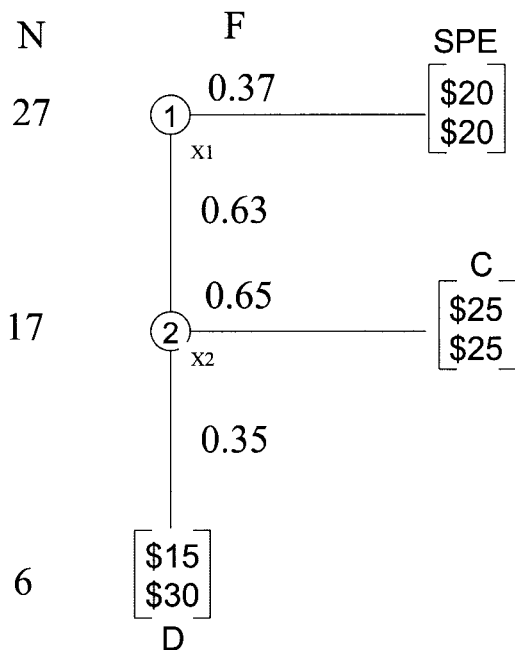

FIGURE 4A. VOLUNTARY TRUST GAME

Note: For abbreviations, see Figure 1 notes.

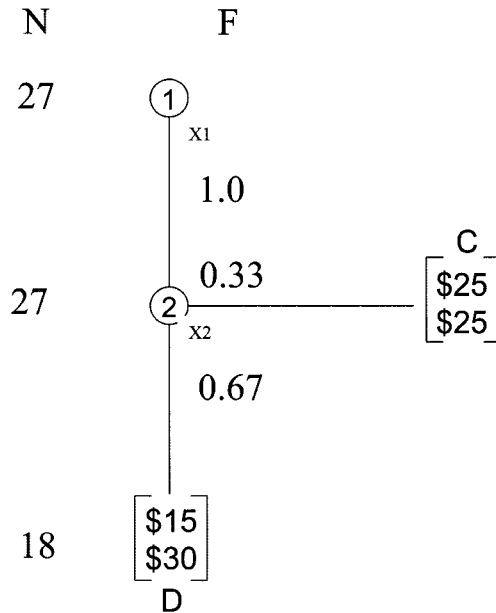

FIGURE 4B. INVOLUNTARY TRUST GAME

Note: For abbreviations, see Figure 1 notes.

(altruistic) outcome; all choose to pass to Player 2 seeking a higher payoff for themselves, and being content to give Player 2 a smaller payoff than is achieved at A, depending upon the final outcome of the move sequence. Secondly, 46 percent offer to cooperate (down), and 50 percent reciprocate.

I. *Utility Versus Exchange: Does Opportunity Cost Matter?*

If reciprocity is perceived as an exchange in which each player gains relative to the default outcome (SPE), then the cooperative outcome must yield an increase in the size of the prize to be split between the two players (see McCabe et al., 2003). Also, Player 2 must believe that (i) Player 1 made a deliberate choice to make this outcome possible, and (ii) incurred an opportunity cost in doing so, i.e., gave up a smaller certain payoff risking a still smaller payoff if C is not attained. It then becomes credible to Player 2 that Player 1 did a favor for Player 2, and reasonably can expect reciprocal action in return. Notice that our argument is in the form

of a constructivist theory that need not characterize the subjects' reasoning, even if it has predictive accuracy; i.e., constructive rationality may predict emergent ecologically rational outcomes, just as CE theory predicts market outcomes not part of the conscious intentions of the agents. McCabe et al. (2001), however, report fMRI brain-imaging data supporting the hypothesis that subjects who cooperate use the "mind reading" circuit modules in their brains (see Baron-Cohen, 1995). This circuitry is not activated in subjects who choose not to cooperate (SPE). In responding to postexperiment questions asking them to write their impressions of their decisions, subjects frequently report that the experiment is all about whether you can trust your counterpart. They do not refer to returning a favor, to reciprocity, an exchange, fairness, etc., suggesting that if their actions are driven by reciprocity motives, such are not part of a self-aware reasoning process.

Reciprocity reasoning motivated the alternative game trees shown in Figure 4 designed to test reciprocity against utility interpretations of choice. In Figure 4A, if Player 1 moves down at

the top the potential prize increases from \$40 to \$50. Player 2 can defect at a cost to Player 1, and can clearly infer that Player 1 deliberately enabled the outcome to increase from (\$20, \$20) to (\$25, \$25). But in Figure 4B Player 2 can see that Player 1 was presented with no voluntary choice to move down. Consequently, Player 1 incurred no opportunity cost to enable Player 2 to achieve C. Player 1 did nothing intentionally for Player 2, and according to reciprocity reasoning, Player 2 incurred no implied debt that needed to be repaid. Player 2 can thus move down with impunity. Consequently, reciprocity theory predicts a greater frequency of right moves by Players 2 in Figure 4A than in Figure 4B. Since only outcomes matter, both own- and other-regarding utility theories predict no difference in Player 2's choices between Figures 4A and 4B. In fact, as shown by the frequency data on the trees, a third of the Players 2 on the right play C, whereas nearly twice that many choose C in the left game.

Intentions have also been found to matter in a study of ultimatum bargaining: "... we show that identical offers in an ultimatum game trigger vastly different rejection rates depending on the other offers available to the proposer" (Armin Falk et al., 1999, p. 2).

### J. Extensive- Versus Normal-Form Games

A fundamental principle of game theory is that rational behavior is invariant to the form—extensive or normal—of the game. Behavior in the extensive and normal forms has been compared by Andrew Schotter et al. (1994), Amnon Rapoport (1997), and McCabe et al. (2000). All three reject the invariance principle, but in the first study the rationality principles they proposed to explain the invariance either failed to predict the differences, "or they were not what we expected" (Schotter et al., 1994, pp. 446–47). Rapoport provides two versions of the "Battle-of-the-Sexes" game to show how order-of-play information in the extensive form allows players to better coordinate their actions. McCabe et al. (2000) argue that the important principle that allows better coordination "derives from the human capacity to read another person's thoughts or intentions by placing themselves in the position and information state of the other person" (p. 4404). This "mind reading" to detect intentions underlies reciprocity.

TABLE 4—BRANCH CONDITIONAL OUTCOMES FOR ONE-SHOT GAME: EXTENSIVE VERSUS NORMAL FORM

Outcome	Extensive-form frequency	Normal-form frequency
(\$7, \$14)	$\frac{0}{26} = 0.0$	$\frac{0}{24} = 0.0$
	$\frac{12}{26} = 0.46$	$\frac{7}{24} = 0.29$
(\$8, \$8)	$\frac{6}{12} = 0.50$	$\frac{1}{7} = 0.14$
(\$12, \$6)	$\frac{6}{12} = 0.50$	$\frac{6}{7} = 0.86$

We summarize here the findings of McCabe et al. (2000) for the trimmed version of the game they study, which is the game we have depicted in Figure 3.

In the extensive form of the game in Figure 3, Player 2 sees the move of Player 1 before Player 2 chooses to move. In this form of the game, intentions can be clearly communicated along the lines storied above. In the normal (or strategic) form of the same game each player chooses a move at each node without knowing whether that node will actually be reached in the move sequence. Decisions are thus contingent on the node being reached and may be irrelevant in determining the payoffs. In the normal form, therefore, we can present the game as an  $n \times m$  matrix of the  $n = 3$  strategies of Player 1—right at node x1, right or down at node x3, and the  $m = 2$  strategies of Player 2, right or down at node x2. Players 1 and 2 each simultaneously choose among these alternatives not knowing the choice of the other.

McCabe et al. (2000) predict that Players 2 will move down at x2, with higher frequency in the extensive than the normal form. They also predict higher rates of cooperation by Players 1 (and lower defection rates) in the extensive than normal forms. Neither own- or other-regarding utility theory can support these predictions. The data are shown in Table 4: 46 percent of the Players 1 offer to cooperate in the extensive form, only 29 percent in the normal form. Similarly, they observe a 50 percent cooperative rate by Players 2 in the extensive form, but only 14 percent in the normal form.

These results and that of others cited above imply that the extensive and normal forms are not played as if they were the same games.

Players' moves signal intentions that are not the same when actually experienced in extensive form as when imagined in a mental experiment corresponding to the normal form. I would argue that experience and its memory in life is an extensive process that encodes context along with outcome. The brain is not naturally adapted to solve all sequential move problems by reducing them to a single strategy vector as in a highly structured game. Apparently, we have a built-in tendency to wait, observe, then decide—a process that conserves cognitive resources by applying them only to contingencies that are realized, and avoids the need for revision, given the inevitable surprises in the less structured games of life.<sup>70</sup> Constructivist modeling glosses over distinctions of which we are unaware that govern the ecology of choice. Experimental designs conditioned only by constructivist thinking, ill-prepare us to collect the data that can inform needed revisions in our thinking. It is both cost effective and faithful to game-theoretic assumptions in experiments to collect move data from each subject under all contingencies, but it distorts interpretability if game forms are not equivalent. The assumptions of game theory, such as those leading to the logical equivalence of the two game forms, should not be imposed on experimental designs, thereby constraining our understanding of behavior beyond those assumptions.

### K. *Neuroeconomics*

Neuroeconomics is concerned with studying the connections between how the mind/brain works—the internal order of the mind—and behavior in (1) individual decision making, (2) social exchange, and (3) institutions such as markets. The working hypothesis is that the brain has evolved different, but interdependent, adaptive mechanisms for each of these tasks involving experience, memory, and perception. The tools include brain-imaging technology and the existence of patients with localized brain lesions associated with specific loss of certain mental functions.

Decision making has drawn the attention of

<sup>70</sup> Any such natural process must be deliberately overcome, constructively, in situations where nature serves us poorly.

neuroscientists who study the deviant behavior of neurological patients with specific brain lesions, such as front lobe (ventromedial prefrontal) damage. Such patients have long been known to be challenged by tasks involving planning and coordination over time, although they score normally on batteries of psychological tests (Antonio R. Damasio, 1994). A landmark experimental study of such patients (compared with controls) in individual decision-making under uncertainty is that of Antoine Bechara et al. (1997). Starting with (fictional) endowments of \$2,000, each subject on each trial draws a card from one of four freely chosen decks (A, B, C, D). In decks (A, B) each card has a payoff value of \$50, whereas in decks (C, D), each is worth \$100. Also, the \$100 decks contain occasional large negative payoff cards, while the \$50 decks have much smaller negative payoff cards. All this must be learned from single card draws in a sequence of trials, with a running tally of cumulative payoff value. A subject performs much better by learning to avoid the \$100 decks in favor of the \$50 decks. By period 60, normal control subjects have learned to draw only from the \$50 (C, D) decks, while the brain-damaged subjects continue to sample disadvantageously the \$100 (A, B) decks. Furthermore, the control subjects shift to the (C, D) decks before they are able to articulate why, in periodic questioning. Also, they pre-register emotional reactions to the (A, B) decks as measured by real-time skin conductivity test (SCT) readings. But the brain-damaged patients tend to verbally rationalize continued sampling of the (A, B) decks, and some types (with damaged amygdala) register no SCT response. Results consistent with those of Bechara et al. (1997) have been reported by Vinod Goel et al. (1997) who study patient performance in a complex financial planning task.

Over 50 years ago experiments with animal behavior demonstrated that motivation was based on relative or forgone reward—opportunity cost—and not on an absolute scale of values generated by the brain. Thus David J. Zeaman (1949) reported experiments in which rats were trained to run for a large reward-motivated goal. When shifted to a small reward, the rats responded by running more slowly than they would to the small reward only. A control group began with a small reward and shifted to a large one, and these rats immediately ran faster than

if the large reward alone was applied. Monkeys similarly respond to comparisons of differential rewards. It is now established that orbitofrontal cortex (just above the eyes) neuron activity in monkeys enable them to discriminate between rewards that are directly related to the animals' relative, as distinct from absolute, preference among rewards such as cereal, apple, and raisins (in order of increasing preference in monkeys) (Leon Tremblay and Schultz, 1999).

Thus suppose A is preferred to B is preferred to C based on choice response. Then neuronal activity is greater for A than for B when the subject is viewing A and B, and similarly for B and C when comparing B and C. But the activity associated with B is much greater when compared with C than when it is compared with A. This is contrary to what one would expect to observe if A, B, and C are coded on a fixed properties scale rather than a relative scale (Tremblay and Schultz, 1999, p. 706).

These studies have a parallel significance for humans. Prospect theory proposes that the evaluation of a gamble depends not on the total asset position but focuses myopically on the opportunity cost, gain or loss, relative to one's current asset position. There is also asymmetry—the effect of a loss looms larger than the effect of a gain of the same magnitude (Kahneman and Tversky, 1979). Barbara A. Mellers et al. (1999) have shown that the emotional response to the outcome of a gamble depends on the perceived value and likelihood of the outcome and on the forgone outcome. It feels better (less bad) to receive \$0 from a gamble when you forgo +\$10 than when you forgo +\$90. (They use the term “counterfactual” rather than “opportunity cost” to refer to the alternative that might have prevailed.) Thus, our ability to form opportunity cost comparisons receive important neurophysiological support from our emotional circuitry. Breiter et al. (2001) use these same principles in the design of a functional magnetic imaging (fMRI) study of human hemodynamic responses to both the expectation and experience of monetary gains and losses under uncertainty. They observed significant activation responses in the amygdala and orbital gyrus, with both activations increasing with the expected value of the gamble. There was also some evidence that the right hemisphere is predominantly active for gains, and the left for losses—a particularly interesting possibility inviting deeper

examination, perhaps by imaging split-brain subjects in the same task. Also see Kip Smith et al. (2002).

The effect of paying subjects is informed by Thut et al. (1997) who compare brain activation under monetary rewards with the feedback of an “OK” reinforcement in a dichotomous choice task. The monetary rewards yielded a significantly higher activation of the orbitofrontal cortex and other related brain areas (see also Schultz, 2000, 2002).

The neural correlates of individual decision-making were extended, by McCabe et al. (2001), to an fMRI study of behavior in two-person strategic interactions in extensive-form trust games like those in Figures 1 to 4. The prior hypothesis, derived from reciprocity theory, the theory-of-mind literature, and supported by imaging results from individual studies of cued thought processes (P. C. Fletcher et al., 1995), was that cooperators would show greater activation in the prefrontal cortex (specifically BA-8) and supporting circuitry, than noncooperators. The control, for comparison with the mental processes used when a subject is playing a human, is for the subject to play a computer knowing the programmed response probabilities and therefore having no need to interpret moves as intentions. The predicted activations were significantly greater, relative to controls, for cooperators than noncooperators, and are consistent with the reciprocity interpretation of behavior discussed above.

#### IV. Conclusions

Cartesian constructivism applies reason to the design of rules for individual action, to the design of institutions that yield socially optimal outcomes, and constitutes the standard socioeconomic science model. But most of our operating knowledge, and ability to decide and perform is nondeliberative. Our brains conserve attentional, conceptual, and symbolic thought resources because they are scarce, and proceeds to delegate most decision-making to autonomic processes (including the emotions) that do not require conscious attention. Emergent arrangements, even if initially constructivist, must have survival properties that incorporate opportunity costs and environmental challenges invisible to constructivist modeling. This leads to an alternative,

ecological concept of rationality: an emergent order based on trial-and-error cultural and biological evolutionary processes. It yields home- and socially grown rules of action, traditions and moral principles that underlie property rights in impersonal exchange, and social cohesion in personal exchange. To study ecological rationality we use rational reconstruction—for example, reciprocity or other-regarding preferences—to examine individual behavior, emergent order in human culture and institutions, and their persistence, diversity, and development over time. Experiments enable us to test propositions derived from these rational reconstructions.

The study of both kinds of rationality has been prominent in the work of experimental economists. This is made plain in the many direct tests of the observable implications of propositions derived from economic and game theory. It is also evident in the great variety of experiments that have reached far beyond the theory to ask why the tests have succeeded, failed, or performed better (under weaker conditions) than was expected. What have we learned, not as final truth, but as compelling working hypotheses for continuing examination?

1. Markets constitute an engine of productivity by supporting resource specialization through trade and creating a diverse wealth of goods and services.
2. Markets are rule-governed institutions providing algorithms that select, process, and order the exploratory messages of agents who are better informed as to their personal circumstances than that of others. As precautionary probes by agents yield to contracts, each becomes more certain of what must be given in order to receive. Out of this interaction between minds through the intermediary of rules the process aggregates the dispersed asymmetric information, converging more-or-less rapidly to competitive equilibria if they exist. Each experimental market carries its own unique mark with a different dynamic path.
3. All this information is captured in the static or time-variable supply and demand environment and must be aggregated to yield efficient clearing prices. We can never fully understand how this process works in the world because the required information is

not given, or available, to any one mind. Thus, for many, the arguments of the Scottish philosophers and of Hayek are obscure and mystical. But we can design experiments in which the information is not given to any participant, then compare market outcomes with efficient competitive outcomes and gauge a market institution's performance.

4. The resulting order is invisible to the participants, unlike the visible gains they reap. Agents discover what they need to know to achieve outcomes optimal against the constraining limits imposed by others.
5. Rules emerge as a spontaneous order—they are found—not deliberately designed by one calculating mind. Initially constructivist institutions undergo evolutionary change adapting beyond the circumstances that gave them birth. What emerges is a form of "social mind" that solves complex organization problems without conscious cognition. This "social mind" is born of the interaction among all individuals through the rules of institutions that have to date survived cultural selection processes.
6. This process accommodates trade-offs between the cost of transacting, attending, and monitoring, and the efficiency of the allocations so that the institution itself generates an order of economy that fits the problem it evolved to solve. Hence, the hundreds of variations on the fine structure of institutions, each designed without a designer to accommodate disparate conditions, but all of them subservient to the reality of dispersed agent information.
7. We understand little about how rule systems for social interaction and markets emerge, but it is possible in the laboratory to do variations on the rules, and thus to study that which is not.
8. Markets require enforcement—voluntary or involuntary—of the rules of exchange. These are: the right possession, its transference by consent, and the performance of promises (Hume). Voluntary enforcement occurs when people in the market reward good services with gratuities or "tips," an example, perhaps, of an emergent cultural norm in which people recognize that tips are part of an informal exchange. If self- or community-enforcement conditions are not

present, the result is unintended consequences for the bad, as markets are compromised or may fail. The game of "trade" must not yield to the game of "steal."

9. Reciprocity, trust, and trustworthiness are important in personal exchange where formal markets are not worth their cost, yet there are gains from exchange to be captured. They are also important in contracting as not every margin of gain at the expense of other can be anticipated and formalized in written contracts.
10. People are not required to be selfish; rather the point of the Scottish philosophers was that people did not have to be good to produce good. Markets economize on information, understanding, rationality, numbers of agents, and virtue.
11. Markets in no way need destroy the foundation upon which they probably emerged—social exchange between family, friends, and associates. This is supported in the studies reported by Henrich (2000). Thus, individuals can be habitual social exchangers and vigorous traders as well, but as in Hayek's "two worlds" text, the ecologically rational coexistence of personal and impersonal exchange is not a self-aware Cartesian construct. Consequently, there is the ever-present danger that the rules of "personal exchange" will be applied inappropriately to govern or modify the extended order of markets. Equally dangerous, the rules of impersonal market exchange may be applied inappropriately to our cohesive social networks.
12. New brain-imaging technologies have motivated neuroeconomic studies of the internal order of the mind and its links with the spectrum of human decision from choice among fixed gambles to choice mediated by market and other institutional rules. We are only at the beginning of this enterprise, but its promise suggests a fundamental change in how we think, observe, and model decision in all its contexts.

#### REFERENCES

- Acheson, James.** "The Lobster Fiefs: Economic and Ecological Effects of Territoriality in the Maine Lobster Industry." *Human Ecology*, September 1975, 2(3), pp. 183–207.
- Anderson, Terry L. and Hill, Peter J.** "The Evolution of Property Rights: A Study of the American West." *Journal of Law and Economics*, April 1975, 18(1), pp. 163–79.
- Arrow, Kenneth J.** "Rationality of Self and Others in an Economic System," in Robin M. Hogarth and Melvin Warren Reder, eds., *Rational choice: The contrast between economics and psychology*. Chicago: University of Chicago Press, 1987, pp. 201–16.
- Backerman, Steven R.; Denton, Michael; Rasantenti, Stephen and Smith, Vernon L.** "Market Power in a Deregulated Electrical Industry." *Journal of Decision Support Systems*, 2001, (30), pp. 357–81.
- Banks, Jeffrey; Olson, Mark; Rasantenti, Stephen and Smith, Vernon L.** "Theory, Experiment and the Federal Communications Commission Spectrum Auctions." *Journal of Economic Behavior and Organization*, 2003 (forthcoming).
- Baron-Cohen, S.** *Mindblindness: An essay on autism and theory of mind*. Cambridge, MA: MIT Press, 1995.
- Bechara, Antoine; Damasio, Hanna; Tranel, Daniel and Damasio, Antonio R.** "Deciding Advantageously Before Knowing the Advantageous Strategy." *Science*, February 28, 1997, 275(5304), pp. 1293–95.
- Berg, Joyce; Dickhaut, John and McCabe, Kevin.** "Risk Preference Instability Across Institutions: A Dilemma." Working paper, Carlson School of Management, University of Minnesota, 1994.
- . "Trust, Reciprocity, and Social History." *Games and Economic Behavior*, July 1995, 10(1), pp. 122–42.
- Binswanger, Hans P.** "Attitudes Toward Risk: Experimental Measurement in Rural India." *American Journal of Agricultural Economics*, August 1980, 62(3), pp. 395–407.
- Bohnet, Iris; Frey, Bruno S. and Huck, Steffen.** "More Order with Less Law: On Contract Enforcement, Trust, and Crowding." *American Political Science Review*, March 2001, 95(1), pp. 131–44.
- Bolton, Gary E.** "A Comparative Model of Bargaining: Theory and Evidence." *American Economic Review*, December 1991, 81(5), pp. 1096–136.
- Bolton, Gary E; Katok, Elena and Zwick, Rami.** "Dictator Game Giving: Rules of Fairness versus Acts of Kindness." *International Journal*

- of *Game Theory*, July 1998, 27(2), pp. 269–99.
- Bolton, Gary E and Ockenfels, Axel.** “ERC: A Theory of Equity, Reciprocity, and Competition.” *American Economic Review*, March 2000, 90(1), pp. 166–93.
- Breiter, Hans C.; Aharon, Itzhak; Kahneman, Daniel; Dale, Anders and Shizgal, Peter.** “Functional Imaging of Neural Responses to Expectancy and Experience of Monetary Gains and Losses.” *Neuron*, May 2001, 30(2), pp. 619–39.
- Bronfman, Corrine; McCabe, Kevin; Porter, David; Rassenti, Stephen and Smith, Vernon L.** “An Experimental Examination of the Walrasian Tâtonnement Mechanism.” *RAND Journal of Economics*, Winter 1996, 27(4), pp. 681–99.
- Burnham, Terence C.** “Engineering Altruism: An Experimental Investigation of Anonymity and Gift Giving.” Unpublished manuscript, Kennedy School of Government, Harvard University, 1998.
- Burnham, Terence; McCabe, Kevin and Smith, Vernon L.** “Friend-or-Foe Intentionality Priming in an Extensive Form Trust Game.” *Journal of Economic Behavior and Organization*, September 2000, 43(1), pp. 57–73.
- Camera, Gabriele; Noussair, Charles and Tucker, Steven.** “Rate-of-Return Dominance and Efficiency in an Experimental Economy.” *Economic Theory*, 2003 (forthcoming).
- Camerer, Colin F.** *Behavioral game theory: Experiments on strategic interaction*. Princeton, NJ: Princeton University Press, 2002.
- Camerer, Colin and Ho, Teck-Hua.** “Experience-Weighted Attraction Learning in Normal Form Games.” *Econometrica*, July 1999, 67(4), pp. 827–74.
- Camerer, Colin; Ho, Teck-Hua and Chong, Juin-Kuan.** “Behavioral Game Theory: Thinking, Learning, and Teaching.” Nobel Symposium on Behavioral and Experimental Economics, Stockholm, December 2001.
- Camerer, Colin and Weigelt, Keith.** “Experimental Tests of a Sequential Equilibrium Model.” *Econometrica*, January 1988, 56(1), pp. 1–36.
- Cason, Timothy and Friedman, Daniel.** “An Empirical Analysis of Price Formation in Double-Auction Markets,” in D. Friedman and J. Rust, eds., *The double auction*. Redwood City, CA: Addison-Wesley, 1993, pp. 253–83.
- Chu, Yun Peng and Chu, Ruey Ling.** “The Subsistence of Preference Reversals in Simplified and Marketlike Experimental Settings: A Note.” *American Economic Review*, September 1990, 80(4), pp. 902–11.
- Coase, Ronald H.** “The Problem of Social Cost.” *Journal of Law and Economics*, October 1960, 3(1), pp. 1–44.
- \_\_\_\_\_. “The Lighthouse in Economics.” *Journal of Law and Economics*, October 1974, 17(2), pp. 357–76.
- Coricelli, Giorgio; McCabe, Kevin and Smith, Vernon L.** “Theory-of-Mind Mechanism in Personal Exchange,” in G. Hatano, N. Okada, and H. Tanabe, eds., *Affective minds*. Amsterdam: Elsevier, 2000.
- Cosmides, Leda and Tooby, John.** “Cognitive Adaptations for Social Exchange,” in Jerome H. Barkow, Leda Cosmides, and John Tooby, eds., *The adapted mind*. New York: Oxford University Press, 1992, pp. 163–228.
- Cox, James C. and Grether, David M.** “The Preference Reversal Phenomenon: Response Mode, Markets and Incentives.” *Economic Theory*, April 1996, 7(3), pp. 381–405.
- Damasio, Antonio R.** *Descartes’ error: Emotion, reason, and the human brain*. New York: G. P. Putnam, 1994.
- Davis, Douglas D. and Holt, Charles A.** *Experimental economics*. Princeton, NJ: Princeton University Press, 1993.
- Deck, Cary; McCabe, Kevin and Porter, David.** “Why Stable Flat Money Hyperinflates: Results from an Experimental Economy.” Unpublished manuscript, Department of Economics, University of Arkansas, 2001.
- Deck, Cary and Wilson, Bart.** “Tracking Customer Search to Price Discriminate.” Working paper, Interdisciplinary Center for Economic Science, George Mason University, 2002.
- Denton, Michael J.; Rassenti, Stephen J. and Smith, Vernon L.** “Spot Market Mechanism Design and Competitiveness Issues in Electric Power.” *Journal of Economic Behavior and Organization*, April 2001, 44(4), pp. 435–53.
- de Waal, Frans B. M.** “Food Sharing and Reciprocal Obligations Among Chimpanzees.” *Journal of Human Evolution*, May 1989, 18(5), pp. 433–59.
- \_\_\_\_\_. “Food Transfers Through Mesh in Brown Capuchins.” *Journal of Comparative Psychology*, December 1997, 111(4), pp. 370–78.

- Donahue, George.** "The U.S. Air Transportation System: A Bold Vision for Change." Paper prepared for the Commission on the Future of the U.S. Airspace Industry, September 19, 2002.
- Dufwenberg, Martin; Lindqvist, Tobias and Moore, Evan.** "Bubbles and Experience: An Experiment on Speculation." Working paper, Department of Economics, Stockholm University, January 2003.
- Eckel, Catherine C. and Grossman, Philip J.** "Altruism in Anonymous Dictator Games." *Games and Economic Behavior*, October 1996, 16(2), pp. 181–91.
- Ellickson, Robert C.** *Order without law: How neighbors settle disputes*. Cambridge, MA: Harvard University Press, 1991.
- Erev, Ido and Roth, Alvin E.** "Predicting How People Play Games: Reinforcement Learning in Experimental Games with Unique, Mixed Strategy Equilibria." *American Economic Review*, September 1998, 88(4), pp. 848–81.
- Falk, Armin; Fehr, Ernst and Fischbacher, Urs.** "On the Nature of Fair Behavior." Working Paper No. 17, University of Zurich, August 1999.
- Fehr, Ernst and Gächter, Simon.** "Do Incentive Contracts Crowd Out Voluntary Cooperation?" Working Paper No. 34, University of Zurich, April 2002.
- Fehr, Ernst and Schmidt, Klaus M.** "A Theory of Fairness, Competition, and Cooperation." *Quarterly Journal of Economics*, August 1999, 114(3), pp. 817–68.
- Fiske, Alan Page.** *Structures of social life: The four elementary forms of human relations*. New York: Free Press, 1991.
- Fletcher, P. C.; Happé, F.; Frith, U.; Baker, S. C.; Dolan, R. J.; Frakowiak, R. S. J. and Frith, C. D.** "Other Minds in the Brain: A Functional Imaging Study of 'Theory of Mind' in Story Comprehension." *Cognition*, November 1995, 57(2), pp. 109–28.
- Forsythe, Robert; Horowitz, Joel L.; Savin, N. E. and Sefton, Martin.** "Fairness in Simple Bargaining Experiments." *Games and Economic Behavior*, May 1994, 6(3), pp. 347–69.
- Forsythe, Robert; Nelson, Forrest; Neumann, George R. and Wright, Jack.** "Anatomy of an Experimental Political Stock Market." *American Economic Review*, December 1992, 82(5), pp. 1142–61.
- Forsythe, Robert; Rietz, Thomas A. and Ross, Thomas W.** "Wishes, Expectations and Actions: A Survey on Price Formation in Election Stock Markets." *Journal of Economic Behavior and Organization*, May 1999, 39(1), pp. 83–110.
- Fouraker, Lawrence E. and Siegel, Sidney.** *Bargaining behavior*. New York: McGraw-Hill, 1963.
- Franciosi, Robert; Kujal, Praveen; Michelitsch, Roland; Smith, Vernon and Deng, Gang.** "Fairness: Effect on Temporary and Equilibrium Prices in Posted-Offer Markets." *Economic Journal*, July 1995, 105(431), pp. 938–50.
- Freuchen, Peter.** *Peter Freuchen's book of the eskimos*. Cleveland, OH: World Publishing Co., July 1961.
- Friedman, Daniel.** "On the Efficiency of Double Auction Markets." *American Economic Review*, March 1984, 74(1), pp. 60–72.
- \_\_\_\_\_. "The Double Auction Market Institution: A Survey," in D. Friedman and J. Rust, eds., *The double auction market: Institutions, theory, and evidence*. Reading, MA: Addison-Wesley Publishing Co., 1993, pp. 3–25.
- Friedman, Milton and Savage, L. J.** "The Utility Analysis of Choices Involving Risk." *Journal of Political Economy*, August 1948, 56(4), pp. 279–304.
- Fuster, Joaquin M.** *Memory in the cerebral cortex: An empirical approach to neural networks in the human and nonhuman primate*. Cambridge, MA: MIT Press, 1999.
- Gazzaniga, Michael S.** *The mind's past*. Berkeley, CA: University of California Press, 1998.
- Gazzaniga, Michael S.; Ivry, Richard B. and Mangun, G.** *Cognitive neuroscience: The biology of the mind*. New York: Norton, 1998.
- Gigerenzer, Gerd; Todd, Peter M. and the ABC Research Group.** *Simple heuristics that make us smart*. New York: Oxford, 1999.
- Goel, Vinod; Grafman, Jordan; Tajik, Jinous; Gana, Sheldon and Danto, David.** "A Study of the Performance of Patients with Frontal Lobe Lesions in a Financial Planning Task." *Brain*, October 1997, 120(10), pp. 1805–22.
- Goldberger, Arthur S.** "Heritability." *Economica*, November 1979, 46(184), pp. 327–47.
- Hawkes, Kristen.** "Showing Off: Tests of an Hypothesis about Men's Foraging Goals." *Ethology and Sociobiology*, January 1991, 12(1), pp. 29–54.
- Hayek, Friedrich A.** *The sensory order: An inquiry into the foundations of theoretical*

- psychology. Chicago: University of Chicago Press, 1952.
- \_\_\_\_\_. *The constitution of liberty*. Chicago: University of Chicago Press, 1960.
- \_\_\_\_\_. *Studies in philosophy, politics and economics*. Chicago: University of Chicago Press, 1967.
- \_\_\_\_\_. *Law, legislation, and liberty, volume I, rules and order*. Chicago: University of Chicago Press, 1973.
- \_\_\_\_\_. "Competition as a Discovery Procedure," in *The essence of Hayek*. Stanford, CA: Hoover Institution Press, 1984, pp. 254–65.
- \_\_\_\_\_. *The fatal conceit: The errors of socialism*. Chicago: University of Chicago Press, 1988.
- \_\_\_\_\_. "Adam Smith (1723–1790): His Message in Today's Language," in *The trend of economic thinking: Essays on political economists and economic history*. Chicago: University of Chicago Press, 1991, pp. 119–24.
- Henrich, Joseph.** "Does Culture Matter in Economic Behavior? Ultimatum Game Bargaining Among the Machiguenga of the Peruvian Amazon." *American Economic Review*, September 2000, 90(4), pp. 973–79.
- Hertwig, Ralph and Ortmann, Andreas.** "Experimental Practices in Economics: A Methodological Challenge for Psychologists?" *Behavioral and Brain Sciences*, June 2001, 24(3), pp. 383–451.
- Hoffman, Elizabeth; McCabe, Kevin A.; Shachat, Keith and Smith, Vernon L.** "Preferences, Property Rights, and Anonymity in Bargaining Games." *Games and Economic Behavior*, November 1994, 7(3), pp. 346–80.
- Hoffman, Elizabeth; McCabe, Kevin A. and Smith, Vernon L.** "On Expectations and the Monetary Stakes in Ultimatum Games." *International Journal of Game Theory*, 1996a, 25(3), pp. 289–301.
- \_\_\_\_\_. "Social Distance and Other-Regarding Behavior in Dictator Games." *American Economic Review*, June 1996b, 86(3), pp. 653–60.
- \_\_\_\_\_. "The Impact of Exchange Context on the Activation of Equity in Ultimatum Games." *Experimental Economics*, June 2000, 3(1), pp. 5–9.
- Hoffman, Elizabeth and Spitzer, Matthew L.** "Entitlements, Rights, and Fairness: An Experimental Examination of Subjects' Concepts of Distributive Justice." *Journal of Legal Studies*, June 1985, 14(2), pp. 259–97.
- Hogarth, Robin M. and Reder, Melvin Warren.** *Rational choice: The contrast between economics and psychology*. Chicago: University of Chicago Press, 1987.
- Holt, Charles.** "Industrial Organization: A Survey of Laboratory Research," in J. Kagel and A. Roth, eds., *The handbook of experimental economics*. Princeton, NJ: Princeton University Press, 1995, pp. 349–443.
- Hume, David.** *A treatise of human nature*. London: Penguin Books, 1985 (first published in 1739).
- Kachelmeier, Steven J. and Shehata, Mohamed.** "Examining Risk Preferences under High Monetary Incentives: Evidence from the People's Republic of China." *American Economic Review*, December 1992, 82(5), pp. 1120–41.
- Kagan, Jerome.** *Galen's prophecy: Temperament in human nature*. New York: Basic Books, 1994.
- Kagan, Jerome and Lamb, Sharon.** *The emergence of morality in young children*. Chicago: University of Chicago Press, 1987.
- Kagel, John H. and Roth, Alvin E., eds.** *The handbook of experimental economics*. Princeton, NJ: Princeton University Press, 1995.
- Kahneman, Daniel; Knetsch, Jack L. and Thaler, Richard.** "Fairness as a Constraint on Profit Seeking: Entitlements in the Market." *American Economic Review*, September 1986, 76(4), pp. 728–41.
- \_\_\_\_\_. "Fairness and the Assumptions of Economics," in R. Thaler, ed., *Quasi rational economics*. New York: Russell Sage Foundation, 1991, pp. 220–35.
- Kahneman, Daniel and Tversky, Amos.** "Prospect Theory: An Analysis of Decision Under Risk." *Econometrica*, March 1979, 47(2), pp. 263–91.
- Kaplan, Hillard and Hill, Kim.** "Food Sharing among Ache Foragers: Tests of Explanatory Hypotheses." *Current Anthropology*, April 1985, 26(2), pp. 223–46.
- Ketcham, Jon; Smith, Vernon L. and Williams, Arlington.** "A Comparison of Posted-Offer and Double-Auction Pricing Institutions." *Review of Economic Studies*, October 1984, 51(4), pp. 595–614.
- Knowlton, Barbara J.; Mangels, Jennifer A. and Squire, Larry R.** "A Neostriatal Habit Learn-

- ing System in Humans." *Science*, September 6, 1996, 273(5280), pp. 1399–402.
- Lazzarini, Sergio G.; Miller, Gary and Zenger, Todd.** "Order with Some Law: Complementarity vs. Substitution of Formal and Informal Arrangements." Interdisciplinary Conference on Trust and Reciprocity in Experimental Economics, Washington University, St. Louis, October 11–12, 2002.
- Ledyard, John D.** "The Scope of the Hypothesis of Bayesian Equilibrium." *Journal of Economic Theory*, June 1986, 39(1), pp. 59–82.
- Lopes, Lola.** "The Rhetoric of Irrationality." *Theory and Psychology*, 1991, 1(1), pp. 65–82.
- Lykken, David T.** *The antisocial personalities*. Hillsdale, NJ: Lawrence Erlbaum Associates, 1995.
- Markowitz, Harry.** "The Utility of Wealth." *Journal of Political Economy*, April 1952, 60(2), pp. 151–58.
- McCabe, Kevin A.; Houser, Daniel; Ryan, Lee; Smith, Vernon L. and Trouard, Theodore.** "A Functional Imaging Study of Cooperation in Two-person Reciprocal Exchange." *Proceedings of the National Academy of Sciences*, September 25, 2001, 98(20), pp. 11832–35.
- McCabe, Kevin A.; Rassenti, Stephen J. and Smith, Vernon L.** "Smart Computer-Assisted Markets," *Science*, October 1991, 254(5031), pp. 534–38.
- \_\_\_\_\_. "Designing a Uniform-Price Double Auction: An Experimental Evaluation," in D. Friedman and J. Rust, eds., *The double auction market: Institutions, theory, and evidence*. Reading, MA: Addison-Wesley Publishing Co., 1993, pp. 307–32.
- \_\_\_\_\_. "Game Theory and Reciprocity in Some Extensive Form Experimental Games." *Proceedings of the National Academy of Sciences*, September 16, 1996, 93(23), pp. 13421–28.
- McCabe, Kevin A.; Rigdon, Mary L. and Smith, Vernon L.** "Positive Reciprocity and Intentions in Trust Games." *Journal of Economic Behavior and Organization*, 2003 (forthcoming).
- McCabe, Kevin A. and Smith, Vernon L.** "A Comparison of Naïve and Sophisticated Subject Behavior with Game Theoretic Predictions." *Proceedings of the National Academy of Sciences*, March 28, 2000, 97(7), pp. 3777–81.
- \_\_\_\_\_. "Goodwill Accounting and the Process of Exchange," in G. Gigerenzer and R. Selten, eds., *Bounded rationality: The adaptive toolbox*. Cambridge, MA: MIT Press, 2001, pp. 319–40.
- McCabe, Kevin A.; Smith, Vernon L. and LePore, Michael.** "Intentionality Detection and 'Mind-reading': Why Does Game Form Matter?" *Proceedings of the National Academy of Sciences*, April 11, 2000, 97(8), pp. 4404–09.
- Mealy, Linda.** "The Sociobiology of Sociopathy: An Integrated Evolutionary Model." *Behavioral and Brain Sciences*, September 1995, 18(3), pp. 523–99.
- Mellers, Barbara A.; Schwartz, A. and Ritov, I.** "Emotion-Based Choice." *Journal of Experimental Psychology: General*, March 1999, 128(1), pp. 1–14.
- Milgrom, Paul R. and Weber, Robert J.** "A Theory of Auctions and Competitive Bidding." *Econometrica*, September 1982, 50(5), pp. 1089–122.
- Mill, John Stuart.** *Principles of political economy, with some of their applications to social philosophy, volumes 1 and 2*. London: Colonial Press, 1899.
- Miller, Ross M.** "Don't Let Your Robots Grow Up to Be Traders." Working paper, Miller Risk Advisors, 2002.
- Miller, Ross M. and Plott, Charles R.** "Product Quality Signaling in Experimental Markets." *Econometrica*, July 1985, 53(4), pp. 837–72.
- Mullainathan, Sendhil and Thaler, Richard H.** "Behavioral Economics." *International encyclopedia of the social and behavioral sciences, volume II*. Oxford: Pergamon, 2001, pp. 1094–99.
- Myerson, Roger B.** *Game theory: Analysis of conflict*. Cambridge, MA: Harvard University Press, 1991.
- North, Douglass Cecil.** *Structure and change in economic history*. New York: Norton, 1981.
- Olson, Mark; Rassenti, Stephen; Smith, Vernon L. and Rigdon, Mary.** "Market Design and Motivated Human Trading Behavior in Electricity Markets." *Institute of Industrial Engineering Transactions*, 2003 (forthcoming).
- Ortmann, Andreas; Fitzgerald, John and Boeing, Carl.** "Trust, Reciprocity, and Social History: A Re-examination." *Experimental Economics*, June 2000, 3(3), pp. 81–100.

- Ostrom, Elinor.** *Governing the commons: The evolution of institutions for collective action.* Cambridge: Cambridge University Press, 1990.
- Pillutla, Madan; Malhotra, Deepak and Mur-nighan, J. Keith.** "Attributions of Trust and the Calculus of Reciprocity." *Journal of Experimental Social Psychology*, 2003 (forthcoming).
- Pinker, Steven.** *The language instinct.* New York: W. Morrow and Co., 1994.
- \_\_\_\_\_. *The blank slate: The modern denial of human nature.* New York: Viking, 2002.
- Plott, Charles R.** "Research on Pricing in a Gas Transportation Network." Office of Economic Policy Technical Report No. 88-2. Federal Energy Regulatory Commission, Washington, DC, July 1988.
- \_\_\_\_\_. "Equilibrium, Equilibration, Information and Multiple Markets: From Basic Science to Institutional Design." Nobel Symposium, Behavioral and Experimental Economics, Grand Hotel Saltsjobaden, December 4-6, 2001.
- Plott, Charles R. and Sunder, Shyam.** "Efficiency of Experimental Security Markets with Insider Information: An Application of Rational-Expectations Models." *Journal of Political Economy*, August 1982, 90(4), pp. 663-98.
- \_\_\_\_\_. "Rational Expectations and the Aggregation of Diverse Information in Laboratory Securities Markets." *Econometrica*, September 1988, 56(5), pp. 1085-118.
- Plott, Charles R. and Uhl, Jonathan T.** "Competitive Equilibrium with Middlemen: An Empirical Study." *Southern Economic Journal*, April 1981, 47(4), pp. 1063-71.
- Plott, Charles R. and Wilde, Louis.** "Professional Diagnosis vs. Self-Diagnosis: An Experimental Examination of Some Special Features of Markets with Uncertainty," in V. L. Smith, ed., *Research in experimental economics*, volume 2. Greenwich, CT: JAI Press, 1982, pp. 63-112.
- Porter, David and Smith, Vernon L.** "Stock Market Bubbles in the Laboratory." *Applied Mathematical Finance*, December 1994, 1, pp. 111-27.
- Rabin, Matthew.** "Incorporating Fairness into Game Theory and Economics." *American Economic Review*, December 1993, 83(5), pp. 1281-302.
- Rapoport, Amnon.** "Order of Play in Strategically Equivalent Games in Extensive Form." *International Journal of Game Theory*, 1997, 26(1), pp. 113-36.
- Rassenti, Stephen; Smith, Vernon L. and Bulfin, R.** "A Combinatorial Auction Mechanism for Airport Time Slot Allocation." *Bell Journal of Economics*, Autumn 1982, 13(2), pp. 402-17.
- Rassenti, Stephen; Smith, Vernon L. and Wilson, Bart J.** "Using Experiments to Inform the Privatization/Deregulation Movement in Electricity." *Cato Journal*, Winter 2002, 21(3), pp. 515-44.
- \_\_\_\_\_. "Controlling Market Power and Price Spikes in Electricity Networks: Demand-side Bidding." *Proceedings of the National Academy of Sciences*, March 2003, 100(5), pp. 2998-3003.
- Rosenthal, Robert W.** "Games of Perfect Information, Predatory Pricing and the Chain-Store Paradox." *Journal of Economic Theory*, August 1981, 25(1), pp. 92-100.
- Satterthwaite, Mark.** "Strategy-Proof Allocation Mechanisms," in J. Eatwell, M. Milgate, and P. Newman, eds., *The new Palgrave*, volume 4. London: Macmillan, 1987, pp. 518-20.
- Schotter, Andrew; Weigelt, Keith and Wilson, Charles.** "A Laboratory Investigation of Multiperson Rationality and Presentation Effects." *Games and Economic Behavior*, May 1994, 6(3), pp. 445-68.
- Schultz, Wolfram.** "Multiple Reward Signals in the Brain." *Nature Reviews: Neuroscience*, December 2000, 1(3), pp. 199-207.
- \_\_\_\_\_. "Getting Formal with Dopamine and Reward." *Neuron*, October 2002, 36(2), pp. 241-63.
- Schwartz, T. and Ang, J. S.** "Speculative Bubbles in the Asset Market: An Experimental Study." Paper presented at the American Finance Association meeting, Atlanta, December, 1989.
- Segal, Nancy L.** *Entwined lives: Twins and what they tell us about human behavior.* New York: Plume, 1999.
- Selten, Reinhard.** "Reexamination of the Perfectness Concept for Equilibrium Points in Extensive Games." *International Journal of Game Theory*, 1975, 4, pp. 25-55.
- Siegel, Sidney.** "Theoretical Models of Choice and Strategy Behavior." *Psychometrika*, 1959, 24, pp. 303-16.
- Siegel, Sidney and Fouraker, Lawrence E.** *Bargaining and group decision making: Experi-*

- ments in bilateral monopoly*. New York: McGraw-Hill, 1960.
- Simon, Herbert Alexander.** *The sciences of the artificial*, 3rd ed. Cambridge, MA: MIT Press, 1981, 1996.
- Smith, Adam.** *The theory of moral sentiments*. Indianapolis, IN: Liberty Classics, 1759 (re-published in 1982).
- \_\_\_\_\_. *An enquiry into the nature and causes of the wealth of nations*. Indianapolis, IN: Liberty Classics, 1776 (republished in 1981).
- Smith, Kip; Dickhaut, John; McCabe, Kevin and Pardo, José V.** "Neuronal Substrates for Choice Under Ambiguity, Risk, Gains, and Losses." *Management Science*, June 2002, 48(6), pp. 711–18.
- Smith, Vernon L.** "An Experimental Study of Competitive Market Behavior." *Journal of Political Economy*, April 1962, 70(12), pp. 111–37.
- \_\_\_\_\_. "Experimental Economics: Induced Value Theory." *American Economic Review*, May 1976 (*Papers and Proceedings*), 66(2), pp. 274–79.
- \_\_\_\_\_. "Relevance of Laboratory Experiments to Testing Resource Allocation Theory," in Jan Kmenta and James Bernard Ramsey, eds., *Evaluation of econometric models*. New York: Academic Press, 1980, pp. 345–77.
- \_\_\_\_\_. "Microeconomic Systems as an Experimental Science." *American Economic Review*, December 1982, 72(5), pp. 923–55.
- \_\_\_\_\_. "Experimental Methods in the Political Economy of Exchange." *Science*, October 10, 1986, 234(4773), pp. 167–73.
- \_\_\_\_\_. *Papers in experimental economics*. Cambridge: Cambridge University Press, 1991.
- \_\_\_\_\_. "The Two Faces of Adam Smith." *Southern Economic Journal*, July 1998, 65(1), pp. 1–19.
- \_\_\_\_\_. *Bargaining and market behavior: Essays in experimental economics*. Cambridge: Cambridge University Press, 2000.
- \_\_\_\_\_. "Method in Experiment: Rhetoric and Reality." *Journal of Experimental Economics*, 2002.
- Smith, Vernon L.; Suchanek, Gerry L. and Williams, Arlington W.** "Bubbles, Crashes and Endogenous Expectations in Experimental Spot Asset Markets." *Econometrica*, September 1988, 56(5), pp. 1119–51.
- Smith, Vernon L. and Szidarovszky, Ferenc.** "Monetary Rewards and Decision Cost in Strategic Interactions," in M. Augier and J. March, eds., *Models of a man: Essays in memory of Herbert A. Simon*. Cambridge, MA: MIT Press, 2003 (forthcoming).
- Smith, Vernon L.; Williams, Arlington W.; Bratton, Kenneth and Vannoni, Michael G.** "Competitive Market Institutions: Double Auctions vs. Sealed Bid-Offer Auctions." *American Economic Review*, March 1982, 72(1), pp. 58–77.
- Soper, Barry and Gigliolotti, Gary.** "Intransitive Cycles: Rational Choice or Random Error?" *Theory and Decision*, 1993, 35, pp. 311–36.
- Sunder, Shyam.** "Market as Artifact: Aggregate Efficiency from Zero Intelligence Traders," in M. Augier and J. March, eds., *Models of a man: Essays in memory of Herbert A. Simon*. Cambridge, MA: MIT Press, 2003 (forthcoming).
- Thaler, Richard H. and Ziemba, William T.** "Parimutuel Betting Markets: Racetracks and Lotteries." *Journal of Economic Perspectives*, Spring 1988, 2(2), pp. 161–74.
- Thut, Gregor; Schultz, Wolfram; Roelcke, Ulrich; Nieuhausmeier, Matthias; Missimer, John; Maguire, R. Paul and Leenders, Klaus L.** "Activation of the Human Brain by Monetary Reward." *NeuroReport*, January 1997, 8(5), pp. 1225–28.
- Tremblay, Leon and Schultz, Wolfram.** "Relative Reward Preference in Primate Orbitofrontal Cortex." *Nature*, April 22, 1999, 39, pp. 466–83.
- Tversky, Amos and Kahneman, Daniel.** "Rational Choice and the Framing of Decisions," in Robin M. Hogarth and Melvin Warren Reder, eds., *Rational choice: The contrast between economics and psychology*. Chicago: University of Chicago Press, 1987, pp. 67–94.
- Umbeck, John.** "The California Gold Rush: A Study of Emerging Property Rights." *Explorations in Economic History*, July 1977, 14(3), pp. 197–226.
- Vickrey, William.** "Counterspeculation, Auctions, and Competitive Sealed Tenders." *Journal of Finance*, March 1961, 16(1), pp. 8–37.
- Viner, Jacob.** "Adam Smith," in D. Irvin, ed., *Essays on the intellectual history of economics*. Princeton, NJ: Princeton University Press, 1991, pp. 248–61.
- Williams, Arlington and Smith, Vernon L.** "Simultaneous Trading in Two Competitive Markets."

- Unpublished manuscript, Indiana University Department of Economics, Bloomington, Indiana, 1986.
- Williams, Arlington W.; Smith, Vernon L.; Ledyard, John O. and Gjerstad, Steven.** "Concurrent Trading in Two Experimental Markets with Demand Interdependence." *Economic Theory*, November 2000, 16(3), pp. 511–28.
- Wilson, Robert B.** "On Equilibria of Bid-Ask Markets," in George R. Feiwel, ed., *Arrow and the ascent of modern economic theory*. New York: New York University Press, 1987, pp. 375–414.
- \_\_\_\_\_. "Strategic Analysis of Auctions," in Robert J. Aumann and Sergi Hart, eds., *Handbook of game theory*. Amsterdam: North-Holland, 1992, pp. 227–79.
- \_\_\_\_\_. "Design of Efficient Auction Procedures," in D. Friedman and J. Rust, eds., *The double auction market: Institutions, theory, and evidence*. Reading, MA: Addison-Wesley Publishing Co., 1993, pp. 125–52.
- \_\_\_\_\_. "Architecture of Power Markets." *Econometrica*, July 2002, 70(4), pp. 1299–1340.
- Zajac, Edward E.** *Political economy of fairness*. Cambridge, MA: MIT Press, 1995.
- \_\_\_\_\_. "What Fairness-and-Denial Research Could Have Told the Florida Supreme Court (and Can Tell the Rest of Us)." *Independent Review*, Winter 2002, 6(3), pp. 377–97.
- Zeaman, David J.** "Response Latency as a Function of the Amount of Reinforcement." *Experimental Psychology*, 1949, 39, pp. 466–83.